



A Division of Star Headlight & Lantern Co., Inc.

SS670 SIREN AMPLIFIER



INSTALLATION AND OPERATING INSTRUCTIONS



455 Rochester Street Avon, NY 14414
Phone: (585) 226-9025 Toll Free Fax: 888-478-2797
www.star1889.com



INSTALLATION INFORMATION

SERIAL NO: _____

MODEL: SS670

PURCHASE DATE: _____

OPTIONS

DEALER: _____

____ Two-Tone Enabled

INSTALLATION DATE: _____

____ Phaser/Man Auxiliary Override

INSTALLER: _____

____ Phaser Disabled

Model and serial number located on bottom of unit

TABLE OF CONTENTS

GENERAL DESCRIPTION	1
INSTALLATION	2-7
SAFETY PRECAUTIONS	2,4
INSTALLER-SELECTABLE OPTIONS	2-3
MOUNTING	4
ELECTRICAL CONNECTIONS	5-7
WIRING DIAGRAM	7
OPERATION	8-11
GENERAL	8
POWER	8
SELECTOR SWITCH	9
MANUAL	10
HORN	10
VOLUME CONTROLS	11
MICROPHONE	11
AUXILIARY INPUT	11
PARK KILL	11
SERVICE	12-14
TROUBLESHOOTING	12
RETURNS	12
PARTS	13
SPECIFICATIONS	13
LIMITED WARRANTY	14

NOTICE

Due to continuous product improvements, we must reserve the right to change any specifications and information, contained in this manual at any time without notice. Signal Vehicle Products, Inc. makes no warranty of any kind with regard to this manual, including, but not limited to, the implied warranties of merchantability and fitness for a particular purpose. Signal Vehicle Products, Inc. shall not be liable for errors contained herein or for incidental or consequential damages in connection with the furnishing, performance, or use of this manual.

GENERAL DESCRIPTION

The SS670 Siren Amplifier is a premium 100W unit designed for single speaker use. The primary operating modes are Phaser, Yelp, Wail, Hands Free, Manual, Alert, and Radio. A Noise Cancelling PA Override and push-button Horn Override are available in all modes. A manual push-button is provided for push-on/push-off tone toggle operation in the Phaser, Yelp, and Wail modes. It also allows manual siren control in the Manual or Alert modes. The Phaser function can be optionally replaced by Two-Tone or disabled entirely with program jumpers. Another feature allows cycling through Wail, Yelp, Phaser and Standby by providing a signal to the horn ring auxiliary wire when the function switch is in the Hands Free (HF) position. A Park Kill option is provided for connection to a door switch, etc. to disable the siren when exiting the vehicle. Radio and PA volume controls are provided on the front panel. The front panel is backlit with LED's for night visibility. This compact unit utilizes short circuit, high voltage, low voltage, and reverse polarity protection systems for maximum service life.

INSTALLATION

SAFETY PRECAUTIONS

Proper installation of the unit is essential for years of safe, reliable operation. Please read all instruction **before** installing the unit. Failure to follow these instructions can cause serious damage to the unit or vehicle and may void warranties.

Qualifications - The installer must have a firm knowledge of basic electricity, vehicle electrical systems and emergency equipment.

Keep These Instructions - Keep these instructions in the vehicle or other safe place for future reference. Advise the vehicle operator of the location.

Unpacking - Inspect contents for shipping damage. If found, alert carrier immediately. Contents should include unit with microphone, mounting bracket w/ 2 bolts, microphone bracket with 2 screws, wiring harness with connector and these instructions. Contact supplier immediately if any components are missing.

INSTALLER SELECTABLE OPTIONS

The SS670 has several options that can be selected during installation. Jumpers on the printed circuit board, inside the case, allow the installer to select these various options. These options should be set before installation of the unit.

Cover Removal - Remove the two Philips head screws located on the **back** of the unit. Slide the bottom cover back and away from the front face of the unit (see diagram below). This cover can be removed completely from the siren unit. **CAUTION!!! DO NOT OVER-TIGHTEN THE SCREWS WHEN REPLACING THEM.**

After the cover has been removed, find the location of the jumpers (see diagram below).

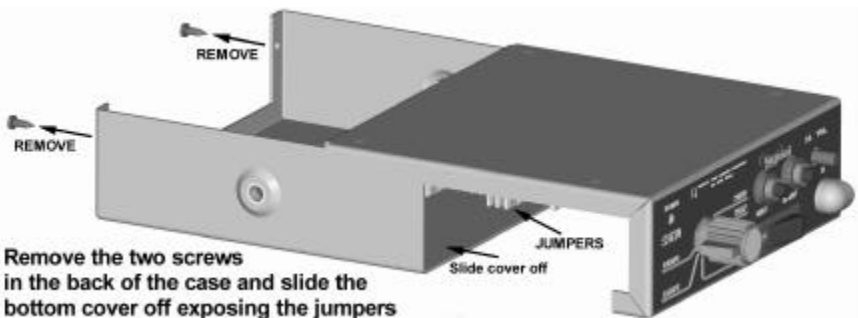

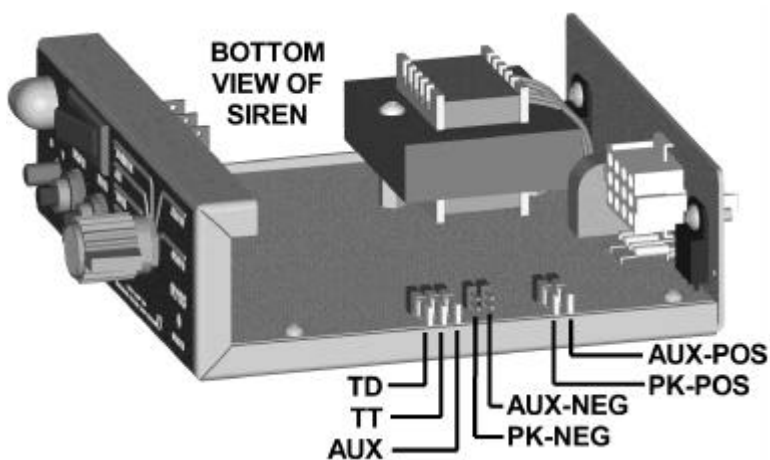

Phaser Disable – (TD – Tone Disable) The Phaser function can be completely disabled by moving the TD jumper from one pin to both pins. This will also disable the Two-Tone sound produced normally when the Manual button is pressed while the Selector Knob (see page 9) is in the PHSR position. (see page 10 for a complete description of the Manual button)

Two-Tone – (TT) A two-tone sound can replace the Phaser sound by moving the TT jumper from the one pin to both pins.

Auxiliary Input Function – (AUX) The Auxiliary Input allows activation of either the Horn or the Manual push-button functions by an external source (switch). This input is usually wired into the vehicle horn switch. The wiring diagram on page 7 shows two connection examples. NOTE: Permanent disconnection of the vehicle horn is NOT recommended.

The siren is shipped from the factory with the auxiliary input option defaulted as the Horn function. To have the auxiliary input activate the Manual function instead of the Horn function, move the AUX jumper from one pin to both pins.

Auxiliary Input Polarity - The auxiliary input (green wire) is normally activated by applying a positive voltage to it. If you would like it activated when it is connected to ground (negative), move the "AUX-POS" option jumper to the "AUX-NEG" pins.

***PLEASE NOTE:** DO NOT place jumpers over both the AUX-POS and AUX-NEG jumpers at the same time. Only one set of pins should have a jumper.*

Park Kill Input Polarity - The Park Kill (Cutout) Input turns off any siren tone output when it is activated, and the tones remain off until a siren control is activated or changed. The wiring diagram on page 7 shows two connection examples.

The park kill input is normally activated when +12VDC is applied to the white wire. To have it activated when ground (negative) is applied to the white wire, move the "PK-POS" option jumper to the "PK-NEG" pins.

***PLEASE NOTE:** DO NOT place jumpers over both the PK-POS and PK-NEG jumpers at the same time. Only one set of pins should have a jumper.*

MOUNTING

SAFETY PRECAUTIONS

For the safety of the installer, vehicle operator, passengers and the community please observe the following safety precautions. **Failure to follow all safety precautions and instructions may result in property damage, injury or death.**



WARNING



- DO NOT mount in air bag deployment area.
- Devices should be mounted only in locations listed in SAE standard J1849.
- Controls should be placed within convenient reach of the driver.
- Assure clearances before drilling in vehicle.
- To prevent internal damage, mounting bolts must not enter case more than 1/4".
- Sound levels produced by attached speakers can cause permanent hearing loss.
- Never operate this unit without adequate hearing protection for you and others in the area. (OSHA 1910.95)

- The SS670 siren may be mounted above the dash, below the dash, on a tunnel, or in a rack with the mounting u-bracket provided.
- Choose a mounting location convenient to the operator and away from any air bag deployment areas.
- Inspect behind mounting area for clearance.
- Assure adequate ventilation to prevent overheating.
- Consider wire routing and access to connections, as well as microphone bracket placement.
- Install mounting bracket to vehicle using 1/4" hardware (not supplied).
- Drill two 1/8" size holes, and install microphone clip using the two screws provided with the clip.
- If mounting in a rack or console, make sure that mounting bolts do not enter case more than 1/4".

ELECTRICAL CONNECTIONS

Electrical connections to the unit are made using a removable connector located on the back (part #SWH-64). You should install the connector on the unit before wiring. If the unit needs service the connector can be easily removed without unwiring the connector.

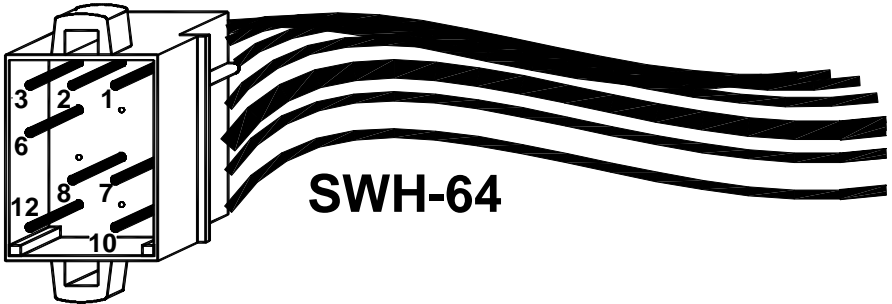

The power supply of the unit must be capable of delivering peak currents up to 30 amps for adequate short circuit protection and reliable operation. The preferred source is directly at the vehicle battery. The unit is internally fused. The wiring diagram on page 7 shows detail of how to wire the siren to the vehicle.

Wire Size and Termination - The wiring diagram shows the minimum wire size used for each connection, along with recommended lead color.

- If a wire is longer than 10 ft., use the next larger wire size.
- Use only high quality crimp connectors.
- Make sure all connections are tight.
- Route wiring to prevent wear, overheating, and interference with air bag deployment.
- Use grommets and sealant when passing through compartment walls.
- Minimize the number of splices to reduce voltage drop.
- Ground connections should only be made to substantial chassis components, preferably directly to the negative of the vehicle battery.
- Install and check all wiring before connection to vehicle battery.

Wiring Connections:

BLACK: (*Terminal 2*) – **Ground:** Connect to the negative of the battery, or to a good chassis ground. Be sure to use minimum size #14 AWG wire.

RED: (*Terminal 1*) – **Power:** Connect to the positive of the battery, or to a high current power buss. A power relay may also be used. Be sure to use minimum size #14 AWG wire.

BROWN: (*Terminals 7 & 12*) – **Speakers:** Connect one brown wire to each terminal or lead of the speaker. Use minimum size #14 AWG wire.

Optional Connections:

BLUE: (*Terminals 3 & 6*) – **Radio:** Used for radio repeat. Connect one blue wire to each terminal of the radio speaker or output connector of the radio. Most radio outputs are isolated, in which polarity would not be important. Radios with polarity sensitive outputs should be connected w/ the blue wire from pin 6 to the positive radio output, and the blue wire from pin 3 to the negative radio output. Use #18 AWG wire.

GREEN: (*Terminal 10*) – **AUX:** Used for remote Manual control. Connect to the horn ring circuit or a remote switch. Circuit may be positive or negative with proper jumper selection. See INSTALLER-SELECTABLE OPTION section (page 3) for jumper details.

NOTE: *Cut lead short if not used & insulate w/ electrical tape.*

WHITE: (*Terminal 8*) – **Park-Kill:** Connect to dome light or added door switch. Circuit may be positive or negative with proper jumper selection. See INSTALLER-SELECTABLE OPTION section (page 3) for jumper details.

NOTE: *Be sure to cut lead short if not used and insulate with electrical tape.*

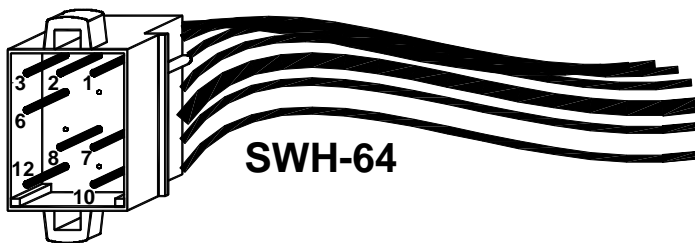

Testing - With the siren running in the WARN mode, test the voltage across pins 1 (red) & 2 (black) of the SWH-64 connector to verify that 12.8-14.0 VDC is present. Test all siren functions after installation to assure proper operation. Test vehicle operation to assure no damage to vehicle.

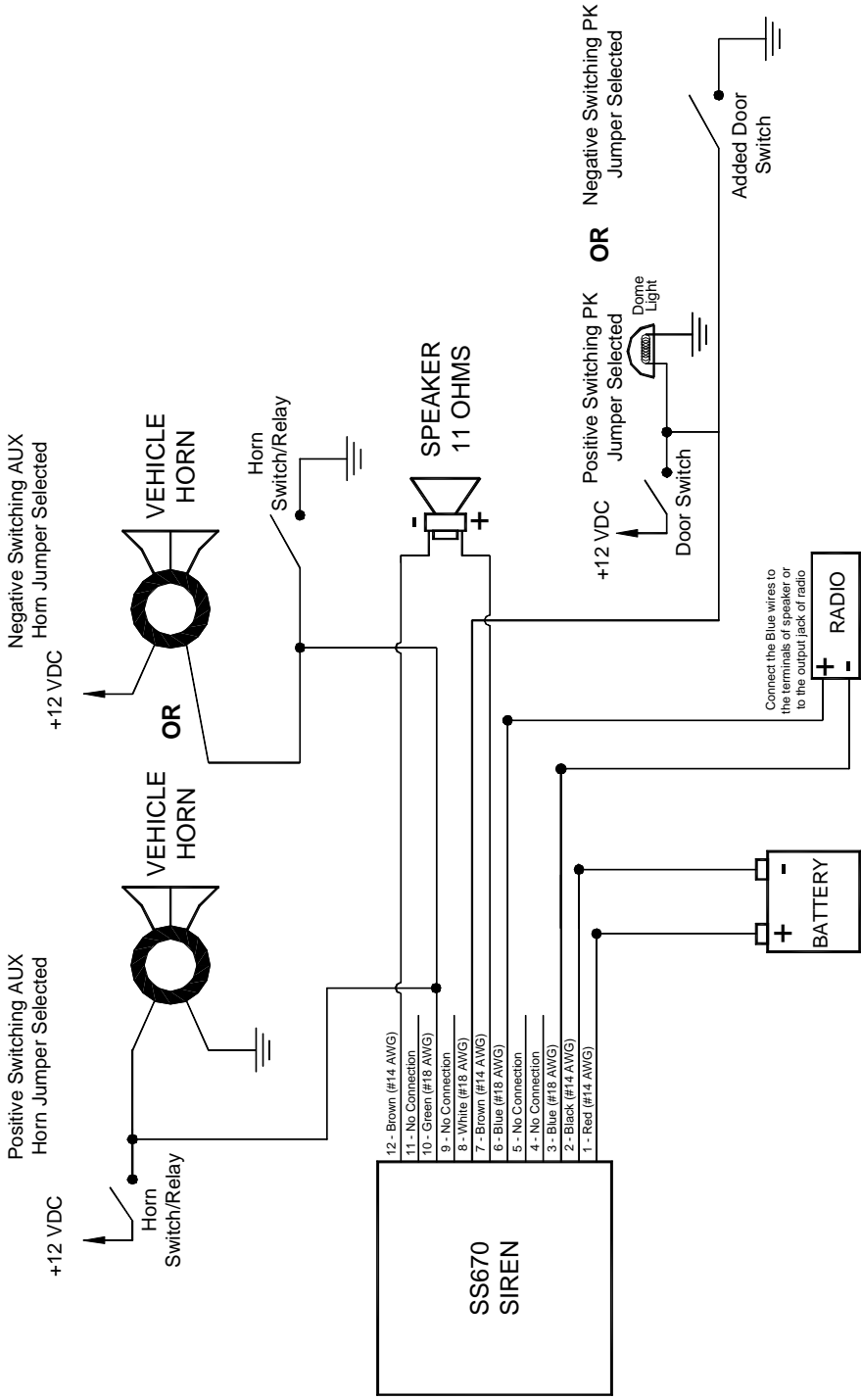

OPERATION

GENERAL

This unit is designed for easy operation under the stress associated with high-speed pursuit. Most siren functions are accessible with one simple motion without repetitive activation of switches or automatic timed switching that can interfere with desired operation.

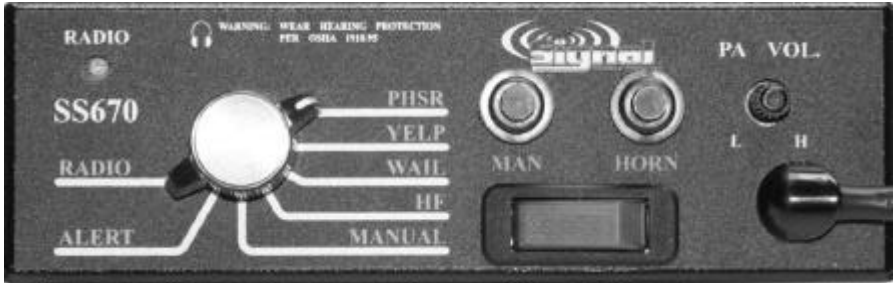

POWER

In order for the siren to function, the power switch must be in the ON position. When turned on, the siren may be activated at the operator's discretion.





SELECTOR SWITCH

The rotary selector switch controls the primary operating function of the siren.

Phaser - (*PSHR*)- Ultra-fast changing tone used for maximum attention.

Yelp - A rapidly changing tone used in congested areas.

Wail - A slower changing tone used on highways.

Hands Free - (*HF*) - Also known as Horn Ring Cycler, allows the user to cycle through Wail, Yelp, and Phaser by repeatedly pressing the horn or other switch connected to the AUX input. Operating any other switch resumes normal operation. Please note that this mode disables the Manual (MAN) push-button selection when a Wail, Yelp, or Phaser tone is cycled to.

Manual - A silent mode that allows push-button Manual (MAN), push-button Horn, and Public Address operation. The siren output *winds down* when the Manual push-button switch is released.

Alert - A silent mode that allows push-button Manual (MAN), push-button Horn and Public Address operation. The siren output *terminates immediately* when the Manual push-button switch is released.

Radio - Also known as Radio Repeat, this function amplifies a radio speaker input for re-broadcast outside the vehicle. No siren tones are available in this position.



MAN

This momentary push-button switch provides a generally quicker changing tone when the selector switch is in the Wail, Yelp, or Phaser positions. (See table below). These quicker tones are used at intersections and very highly congested areas. Pressing the button once changes to the next faster tone and pressing again changes the tone back to the original sound. With the selector switch in the Manual, Alert, or Hands Free position, this switch provides a manually activated Wail siren tone while the button is being held. This is used to momentarily alert motorists or in low noise areas.

Optional operation includes replacement of the Phaser tone with Two-Tone or disabling the Phaser tone entirely. These options are selected during installation and may be governed by State or Local laws.

With Rotary Switch in this Position:	Pressing the MANUAL Push-button Switch Does This:
PHSR	Toggles the Output to TWO-TONE
YELP	Toggles the Output to PHASER
WAIL	Toggles the Output to YELP
HF (Hands Free)	Creates a manual WAIL tone while button is being held that sweeps down when the button is released.
MAN (Manual)	Creates a manual WAIL tone while button is being held that sweeps down when the button is released.
ALERT	Creates a manual WAIL tone while button is being held that stops immediately when the button is released.

(NOTE: PHASER and TWO-TONE may be optionally swapped or disabled via program jumpers. See INSTALLER-SELECTABLE OPTIONS on pages 2-3)

HORN (Air Horn)

This momentary push-button switch provides a simulated air-horn tone while pressed. This can be used to either replace, or to supplement the normal vehicle horn and is useful at intersections or in high noise areas. This tone will override all other siren tones.

VOLUME CONTROLS

The *radio repeat volume* control is recessed in the upper left hand corner of the front face. This should be set when the vehicle is parked. First set the volume level of the vehicle's two-way radio to its normal operating volume. Adjust the siren's rotary selector switch into the RADIO position. Insert a small, flat blade screwdriver into the RADIO volume adjustment port. Turn clockwise direction to increase the sound level.



The *PA volume* control is provided for public address volume. It is located in the upper right hand corner of the front face. This should be set when the vehicle is parked. Set the PA volume to the maximum level with no feedback (squeal).

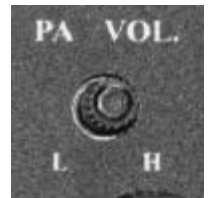

MICROPHONE

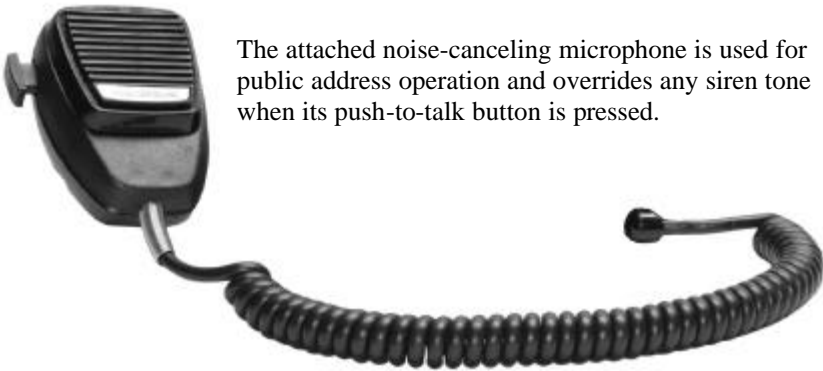

The attached noise-canceling microphone is used for public address operation and overrides any siren tone when its push-to-talk button is pressed.

AUXILIARY INPUT

During installation the auxiliary input (green wire from Terminal 10 on the SWH-64 wiring harness on the back of the siren) may be connected to the vehicle horn ring or other switching device. It provides the same operation as pressing the Horn button or optionally (via internal jumpers) the Manual (MAN) push-button.

PARK KILL (CUTOUT)

During installation, the Park Kill input (the white wire from Terminal 8 on the SWH-64 wiring harness) may be connected to a door switch. It will automatically turn off any siren tone when the door is opened. The siren tone will continue to be cut off even when the door is closed. Changing any switch or input will restore normal function.

SERVICE

This unit is designed to provide years of reliable service under even the worst conditions. Many times there may appear to be a problem with the unit when the true problem is in the speaker(s) or improper installation. The following chart shows typical symptoms and possible causes.

TROUBLESHOOTING

Symptom	Possible Cause	Check
No power	Power switch not turned on Connector loose Siren 15A fuse blown Loose connection at power source	Does back-lighting come on? Do you hear a "pop" when turned on? Is power hooked up backwards? Positive ground vehicle? Do mounting bolts protrude too far into siren housing? Is an external fuse or circuit breaker used? Are the negative leads connected to a good ground?
No siren tone - PA works No siren tone - No sound	High voltage protection Low voltage protection Microphone button stuck Park Kill polarity option set wrong Park Kill activated Bad speaker or speaker wiring	The input voltage must be less than 16 volts. The input must be greater than 10V with the siren turned on. Does microphone button release properly? Is the PK jumper option properly configured? Does the siren work when Park Kill input is disconnected?
No PA	PA volume not set properly	Have you tried turning the PA volume control?
Distorted siren sound	Speaker assembly loose Intermittent Aux. Input connection Low or high vehicle voltage	Is the speaker bell or tip loose? Is the Aux. Input used and wired properly? Input voltage must be between 10 & 16 volts while siren is on.
Intermittent siren tone	High voltage protection Low voltage protection Microphone button activation Circuit breaker in supply connection Shorted speaker or speaker wire	Is the vehicle voltage regulator working properly? Is the connector tight on the back of the unit? Is there a loose connection on a power lead? The input must be greater than 10V with the siren turned on. Is something lying on the microphone? Is a circuit breaker used with at least a 30A rating? Does the speaker have water damage, or is a wire pinched?
Horn function or Manual or Phaser stuck on	Horn switch stuck MAN push-button switch stuck Aux. Input improperly connected Aux. Input Polarity Option set wrong	Does the horn switch return fully when released? Does the MAN push-button switch return fully when released? Is the Aux. Input used and wired properly? Is the AUX jumper option properly configured?
No Radio No or Low Radio	Unit not connected to radio Radio volume too low Radio outputs not isolated and polarity hooked up backwards	Is the radio connected properly to the unit? Can you hear the radio in the vehicle? Have you tried turning the Radio volume control? Are the radio wires connected to the correct polarity from the radio output?
Wrong siren tone	Two-Tone option jumper installed Aux. Input set to wrong function	Is the TT jumper option properly configured? Is the AUX jumper option configured properly?
Phaser not working	Phaser disabled	Is the PD jumper option configured properly?

RETURNS

If you have any questions concerning this or any other SVP product, please contact our **Customer Service Department** at (585) 226-9025.

If a product must be returned for any reason, please contact our Customer Service Department to obtain a Returned Goods Authorization number (RGA#) before you ship the product to SVP. Please write the RGA# clearly on the package near the mailing label.

PARTS

The following parts are available from Signal Vehicle Products:

Part	Description
S30235-15	Siren Top Cover
S30234-15	Siren Bottom Mounting Plate
SWH-64	Wiring Harness
P30069-38	Microphone Bracket with Screws
P30056-16	1/4-20 x 3/8" Hex Locking Bolt
P30028-6	15 Amp Automotive Fuse
P30232-1	Noise Canceling Microphone
P30208-10	Microphone Strain Relief
P30032-8	TIP36C Power Transistor
P30239-1	Rotary Selector Switch Knob
P30147-44P	Mounting Bracket
P30050-14	Case Screws

SPECIFICATIONS

Input Voltage	10 - 16 VDC (negative ground)
Input Current	8.0 Amps @ 13.6 VDC (100W speaker)
Standby Current	Less than 150 mA
Audio Frequency	200Hz - 10 kHz \pm 3db
Audio Output	40 watts @ 13.6 VDC (100W speaker)
Output Power	105 WATTS RMS MAX. (15.0 VDC - 100W speaker)
Siren Frequency	675Hz - 1633Hz
High Voltage Protection	16 - 18 VDC will cause siren output to cease, resumes at normal voltage
Short Circuit Current	30 AMPS (supply circuit must be capable of supplying this)
Operating Temperature	-15° F to +140°F
Controls	7-position rotary switch (Radio, Alert, Man, HF, Wail, Yelp, Phsr) Momentary push-button Horn switch Momentary push-button Manual/Toggle switch Auxiliary input (jumper programmable) for positive or negative horn -Remote Manual or Hands Free operation Park Kill input (jumper programmable) for positive or negative activation Phaser (and Two-Tone) disable (jumper programmable) Two-Tone activation (swaps modes with Phaser) (jumper programmable)
Connections (12-Pin Connector)	Detachable, 12-pin, positive locking connector with pigtail leads. (1) Positive, (1) Negative, (2) Speaker, (2) Radio, Auxiliary, Park Kill
Size	6" Wide, 6-1/2" Deep, 2" High
Shipping Weight	6 lbs.

LIMITED WARRANTY

Signal Vehicle Products warrants this new product to be free from defects in material and workmanship, under normal use and service, for a period of one (1) year from the date of delivery to the first user-purchaser.

During this warranty period the obligation of Signal Vehicle Products is limited to repairing or replacing, as Signal Vehicle Products may elect, any part or parts of such product which after examination by Signal Vehicle Products is determined to be defective in material and/or workmanship.

This warranty does not cover labor charges for removal or re-installation of the product. Fuses and lamps are not covered under this warranty.

This warranty does not extend to any unit that has been subjected to abuse, misuse, improper installation or which has not been adequately maintained, nor to units which have problems related to service or modification at any facility other than the manufacturer.

THERE ARE NO OTHER WARRANTIES, EXPRESSED OR IMPLIED, INCLUDING BUT NOT LIMITED TO, ANY IMPLIED WARRANTIES OF MERCHANTABILITY OR FITNESS FOR A PARTICULAR PURPOSE. IN NO EVENT SHALL SIGNAL VEHICLE PRODUCTS BE LIABLE FOR ANY LOSS OF PROFITS OR ANY INDIRECT OR CONSEQUENTIAL DAMAGES ARISING OUT OF ANY SUCH DEFECT IN MATERIALS OR WORKMANSHIP.



PROUDLY MADE IN THE USA
An ISO 9001 Certified Company



A Division of Star Headlight & Lantern Co., Inc.

455 Rochester Street Avon, NY 14414
Phone: (585) 226-9025 Toll Free Fax: 888-478-2797

www.star1889.com