

# Solid State Headlight Flasher with Select-A-Pattern Technology Isolation Model (ETHFSS-SP-ISO)

## WARNING:

This Flasher will not work on any "ground side switched" system. If you have any questions regarding what type of system your vehicle has, contact SoundOff Signal's Technical Service Department at 1-800-338-7337.

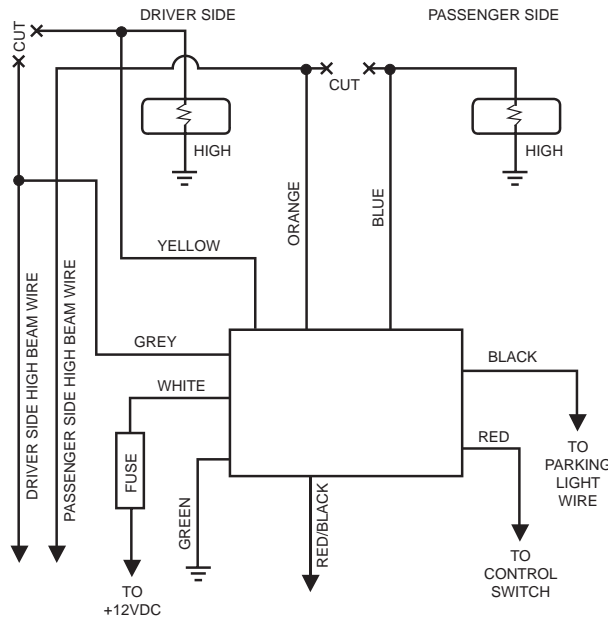

Please see reverse for Technical Specifications



## IMPORTANT NOTICE FOR INSTALLATION INTO DODGE DURANGO OR DODGE DAKOTA

Please refer to page 2 for special installation requirements if you are installing the Flasher into a Dodge Durango or Dodge Dakota. Failing to follow the special installation instructions may cause damage to the head light housing.

Congratulations! You are now the proud owner of the most technically advanced true 100% Solid State Selectable Pattern Headlight Flasher System in the market today. Add to it our never ending commitment to quality, when properly installed this new Flasher System will provide you with years of dependable trouble free service.

The Flasher System will operate a 2 or 4 headlight system on any vehicle with a +10-16 Vdc positive side switched headlight systems.

### NOTE:

When used in dark conditions, the low beam headlights need to be ON for proper illumination, while the highbeam headlights will flash to gain attention and increase the vehicle's visibility.

When the high beam switch is activated, the Flasher system's High Beam Over-Ride (HBOR) is activated and will interrupt the flashing sequence to allow normal high beam function. The HBOR function is automatically disabled with the high beam switch is deactivated allowing the headlight flasher to resume operation.

### NOTE:

Flashing Headlights and Taillight Systems are intended for approved vehicles only. The user of this system is responsible to ensure compliance to any Federal, State, or Municipal regulations, which may apply.

## MOUNTING:

The enclosed headlight flasher has been designed to be water resistant. However, to ensure years of trouble free operation of the flasher system, it should be mounted in a location that is protected from direct water spray and high temperatures.

### GREEN WIRE:

Connect to reliable ground, preferably close to ground post of battery

**BLUE WIRE:** Locate the wire that supplies power to the passenger side high beam. Cut the wire and connect the flashers blue wire to the cut wire end that goes back to the high beam headlight.

**ORANGE WIRE:** Connect the flashers orange wire to the cut wire end that goes back to the vehicles lighting control module (supply).

**YELLOW WIRE:** Locate the wire that supplies power to the driver side high beam. Cut the wire and connect the flashers yellow wire to the cut wire end that goes back to the high beam headlight.

**GREY WIRE:** Connect the flashers grey wire to the cut wire end that goes back to the vehicles lighting control module (supply).

**WHITE WIRE:** Connect to a +10-16Vdc power source capable of providing 15 Amps.

### WARNING:

**DO NOT USE A CIRCUIT BREAKER, FUSIBLE LINK, OR SLOW BLOW TYPE FUSE**

### RED WIRE:

Connect to a powered switch through a user supplied 1 amp fuse.

### BLACK WIRE (OPTIONAL Connection):

If an "Automatic Nighttime Flasher disable" is required (check with state and municipal regulations) simply 'T' or tap this wire into the parking / marker light wire. This feature will disable the flasher whenever the parking / marker lights are turned ON.

To review our Limited Warranty Statement & Return Policy for this or any SoundOff Signal product please visit our website at [www.soundoffsignal.com](http://www.soundoffsignal.com) and select the "Warranty & Returns" link along the left column of our home page. If you have questions regarding this product please contact Technical Services, Monday - Friday, 8 am to 5 pm at 1.800.338.7337, press #4 to skip the automated message. Questions or comments that do not require immediate attention may be emailed to [techsupport@soundoffsignal.com](mailto:techsupport@soundoffsignal.com).

1.800.338.7337. / [www.soundoffsignal.com](http://www.soundoffsignal.com) / Thank you for trusting us with your safety!

# Solid State Headlight Flasher with Select-A-Pattern Technology Isolation Model (ETHFSS-SP-ISO)

ELECTRICAL SPECIFICATIONS	
Input Voltage	10-16Vdc
Output Current:	9.5 Amps / output
Standby Current:	< 10mA
Number of Flash Patterns:	7

Flash Patterns	
Flash Pattern Sequence	FPM (Flashes per Minute)
1. RoadRunner™	115
2. PowerPulse™	180
3. ETM™	215
4. Double Flash	50
5. Q-Switch™	Multi-Pattern
6. Cycle Flash	Multi-Pattern
7. Single Flash	56

## SPECIAL INSTALLATION INSTRUCTIONS FOR DODGE DURANGO AND DODGE DAKOTA

### WARNING!!

This product requires the proper installation of the Night-Time Cutoff circuit. This circuit is controlled by the black wire exiting the Flasher. The black wire must be wired according to the installation drawing and instructions. Failure to do so may result in head damage to the vehicle's headlamp housings at the owner's expense.

The Headlamp Flasher will ONLY operate when the headlamps are switched to OFF position. Whenever the headlamps are activated, the Flasher WILL NOT function. It is the responsibility of the installer to make certain the vehicle operator is aware of this situation.

### Final System Check:

1. Verify Headlight Flasher properly flashes headlights when Flash Enable switch is turned ON.
2. With Flash Enable Switch ON, turn High beam switch ON and verify both high beam headlights turn ON steady.
3. If NTCO is required: With Flash Enable Switch ON, turn parking / marker lights ON and verify Flasher does not function.

### Troubleshooting:

Symptom:	Solution:
No Operation	Verify fuse is not open. Verify voltage of 10-16Vdc is present on Red wire
Interference with Radio equipment	Verify power and ground wires are not connected to same circuit as radio equipment. Connect ground wire as close to ground terminal of battery as practical
Flasher stops functioning when marker lights are turned ON	NTCO (Night Time cut-off) wire is connected to parking / marker lights. If flashing of headlights is allowed at night, remove NTCO wire from marker light wiring.
Headlights turn ON for short time then OFF for a couple of seconds and repeats	Over-current shutdown of the flasher has detected too much load on the flasher. Verify a maximum of 2-55 Watt lamps are connected to each output

### Flash Pattern Selection:

To change the pattern, momentarily touch Red/Blk wire to ground. The pattern will change each time Red/Blk wire is touched to ground.

Once the pattern is selected, the flasher will retain the selected flash pattern.

