

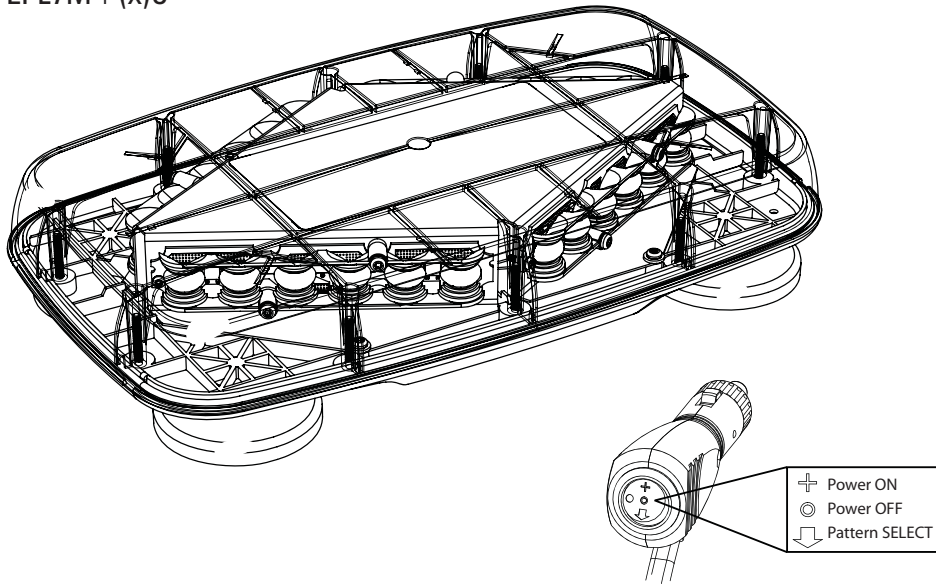

EPL7000 PINNACLE MINI LIGHTBAR MAGNET MOUNT

EPL7M+(x)C



Please see reverse for
Technical Specifications

Important Information:

- Warning devices are strictly regulated and governed by Federal, State and Municipal ordinances. These devices shall be used ONLY on approved vehicles. It is the sole responsibility of the user of these devices to ensure compliance.
- DO NOT connect this device to a strobe power supply. This product is self-contained and does not require an external power supply.



INSTALLATION:

- 1) Determine a clean, flat location (typically the roof) on the vehicle to mount the PINNACLE Mini Lightbar. The PINNACLE Mini Lightbar comes equipped with four magnetic feet. It is the responsibility of the installer and end user to determine whether it is safe to use magnetic mounting hardware for your application. A Permanent Mount version (EPL7PD(x)C) is available. Note: The magnetic character of roof steel varies from vehicle to vehicle. Be sure that your vehicle is capable of providing enough magnetic force to safely secure the PINNACLE Mini Lightbar to the roof.
- 2) A Protective Film has been provided with the PINNACLE Mini Lightbar kit that can be applied to the bottom of each magnet. This film will protect the paint of the vehicle. Apply one donut shaped decal to the bottom of each magnetic foot. Be sure to cover the magnet entirely for maximum protection to the paint finish. Note: Protective film can reduce the magnetic force by as much as 10%.

OPERATION:

Electrical Connections
& Flash Pattern Selection:

See diagram at left for Power ON (+), Power OFF (⊙) and Pattern SELECT (⇩) switch positions. Turn the light on by pressing the Power ON button. To change the flash pattern press and hold the PATTERN SELECT button for one to two (1-2) seconds. The PINNACLE Mini Lightbar will advance one (1) flash pattern and flash the new pattern each time this is done. The PINNACLE Mini Lightbar features non-volatile memory and will recall last pattern used. Selected pattern will remain the default once turned off and can be changed by changing the flash pattern before powering off.



To review our Limited Warranty Statement & Return Policy for this or any SoundOff Signal product please visit our website at www.soundoffsignal.com and select the "Warranty & Returns" link along the left column of our home page. If you have questions regarding this product please contact Technical Services, Monday - Friday, 8 am to 5 pm at 1.800.338.7337, press #4 to skip the automated message. Questions or comments that do not require immediate attention may be emailed to techsupport@soundoffsignal.com.

1.800.338.7337. / www.soundoffsignal.com / Thank you for trusting us with your safety!



EPL7000 PINNACLE MINI LIGHTBAR MAGNET MOUNT

EPL7M+(x)C

TECHNICAL SPECIFICATIONS	
Overall Dimensions:	14.25"L x 8.27"W x 2.93"H
Flash Patterns:	28 flash patterns
Input Voltage Range:	10 - 16 Vdc
Current Consumption:	2 Amps (Avg) - 4 Amps (Max)
# of LEDs:	24 Generation 3 LEDs
Operating Temperature:	-40° to +65° C

Flash Patterns	
Alternating Patterns	FPM (Flashes per Minute)
1. Warp	Alternating
2. Quad	"
3. Quad2	"
4. Quint	"
5. Double2	"
6. Warp 1, 2, 3	"
7. Progressive	"
8. Q-Switch	"
9. Intercycle	"
10. Warp	Whole Bar
11. Quad	"
12. Quad2	"
13. Quint	"
14. Double2	"
15. Warp 1, 2, 3	"
16. Progressive	"
17. Warp	Diagonal
18. Quad	"
19. Quad2	"
20. Quint	"
21. Double2	"
22. Warp 1, 2, 3	"
23. Progressive	"
24. Q-Switch	"
25. Intercycle	"
26. Rotator	"
27. Cycle 1	Random
28. Cycle 2	"

Replacement Parts & Accessories: _____

- PMB3BMG: Replacement Magnetic Foot (each)
- PMB3MGKT: Replacement Magnetic Mount (kit)
- PMB3TDC: Replacement Clear Dome

