

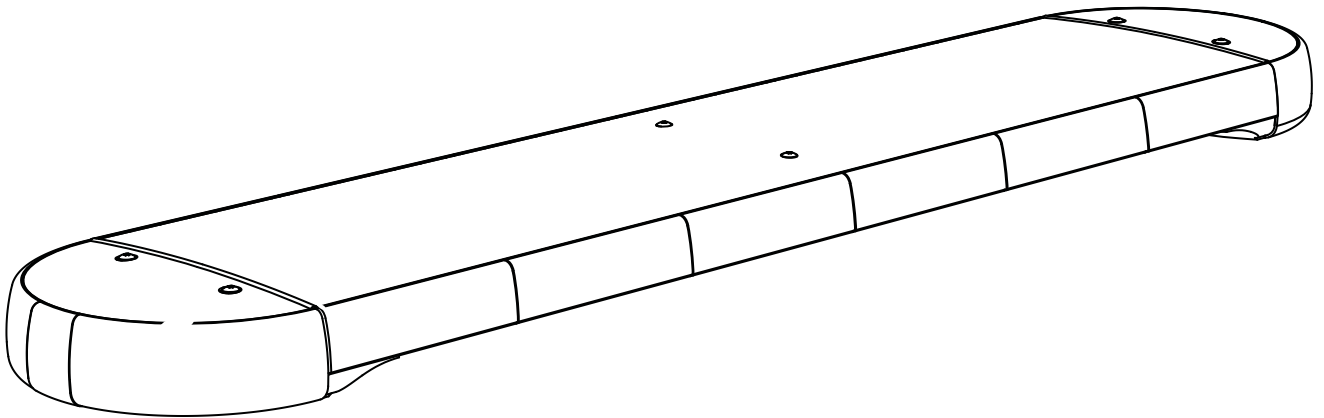

3900 Central Parkway
Hudsonville, MI 49426
toll free 800.338.7337
office 616.896.7100
techsupport@soundoffsignal.com
www.soundoffsignal.com



PINNACLE

Lightbar

**OWNER'S MANUAL &
INSTALLATION
INSTRUCTIONS**

TABLE OF CONTENTS

PAGE	CONTENT
3	TECHNICAL SPECIFICATIONS
4	PRE-INSTALLATION
5	PINNACLE BASICS
6	FIXED HEIGHT BRACKETS AND HOOK MOUNTING
7	FIXED HEIGHT BRACKETS PERMANENT MOUNTING
8-10	ADJUSTABLE HEIGHT BRACKETS AND HOOK MOUNTING
10-11	ELECTRICAL INSTALLATION
12-13	BREAKOUT BOX
13	FLASH PATTERNS AND CONNECTOR INSTRUCTIONS
14	CONTROLLER AND WIRE HARNESS INSTRUCTIONS
15	PINNACLE TROUBLESHOOTING
16	REPLACEMENT PARTS
17	PRODUCT MAINTENANCE
BACK	WARRANTIES AND POLICIES

PRE-INSTALLATION

IMPORTANT NOTICE TO INSTALLER: Make sure to read and understand all instructions and warnings before proceeding with the installation of this product. Ensure that the manual and any warning cards are delivered to the end user of this equipment. Proper installation of the lightbar requires the installer to have a thorough knowledge of automotive electronics, systems, and procedures. Lightbars provide an essential function of an effective visual warning system. The use of the lightbar does not insure that all drivers can or will abide by or react to an emergency warning signal, especially at high rates of speeds or long distances. The operator of the vehicle must never take the right of way for granted and it is the operator's responsibility to proceed safely. The effectiveness of the this lightbar is highly dependant on the correct mounting and wiring. The installer must read and follow the manufacturer's installation instructions and warnings in the manual. The vehicle operator should verify daily that the lightbar is securely fastened to the vehicle and properly functioning before operating vehicle. The lightbar is intended for use by authorized personnel only. It is the user's responsibility to ensure they understand and operate the emergency warning devices in compliance with the applicable city, state and federal laws and regulations. (SoundOff Signal assumes no liability for any loss resulting from the use of this warning device.)

Unpack box:

1. Remove the light bar and packaging.
2. Save packaging for later shipping.
3. Check components/contents.
4. Please reference this instruction manual for proper wiring and installation.

Tools Required for Installation:

- 5/32" Allen Driver
- 7/16" Socket with ratchet
- T-25 Torx Driver
- Phillips Head Screwdriver
- Electric Drill with #30 (.128 dia.) drill bit
- 1 1/4" Hole Saw

Components/Contents

Standard Equipment

- 1- PINNACLE Lightbar
- 1- Roof Side Cable Grommet (cable specific)

Controller

- 1- Breakout Box (DSC Option)
- 1- Wire Harness

Optional Mounting Kits

- 2- Adjustable Height Mounting Brackets (OR)
- 2- Fixed Height Mounting Brackets
- 1- Specific Vehicle Hook w/ Hardware Kit (OR)
- 1- Specific Mounting Hardware Kit

**Kits will vary with each bar

WARNING - DRILLING ANY HOLES INTO THE LIGHTBAR IS NOT RECOMMENDED! THE RISK OF DAMAGING INTERNAL COMPONENTS AND THE RESULTING FAILURE OF THE LIGHTBAR WILL VOID ANY WARRANTY OF THIS PRODUCT.

**SoundOff
Signal** 

PINNACLE
Lightbar 

At anytime during your installation process, feel free to call our technical support line at 1-800-338-7337. Press #4 to skip automated message. You can also visit our website at www.soundoffsignal.com or e-mail technical assistance at techsupport@soundoffsignal.com.

PINNACLE BASICS

This is a basic configuration showing many of the features offered. Your PINNACLE may have a different configuration. This diagram should only be used as a reference.

TOP VIEW WITH COVER ON

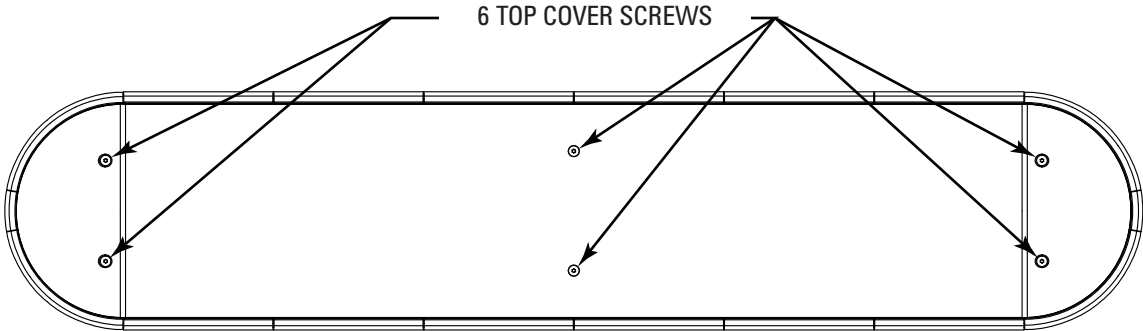

TOP VIEW WITH COVER OFF

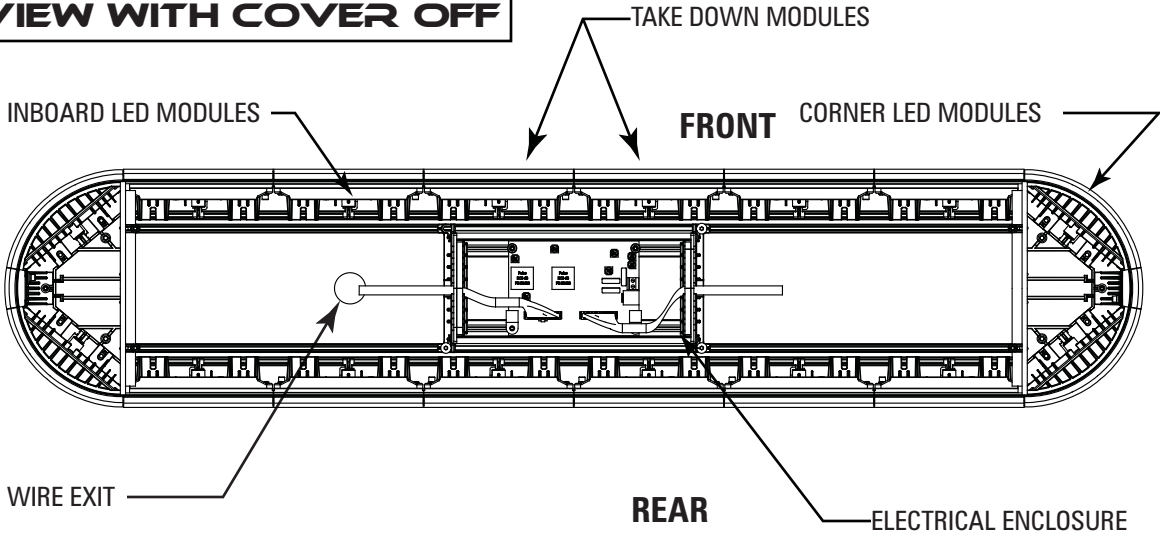

BOTTOM VIEW

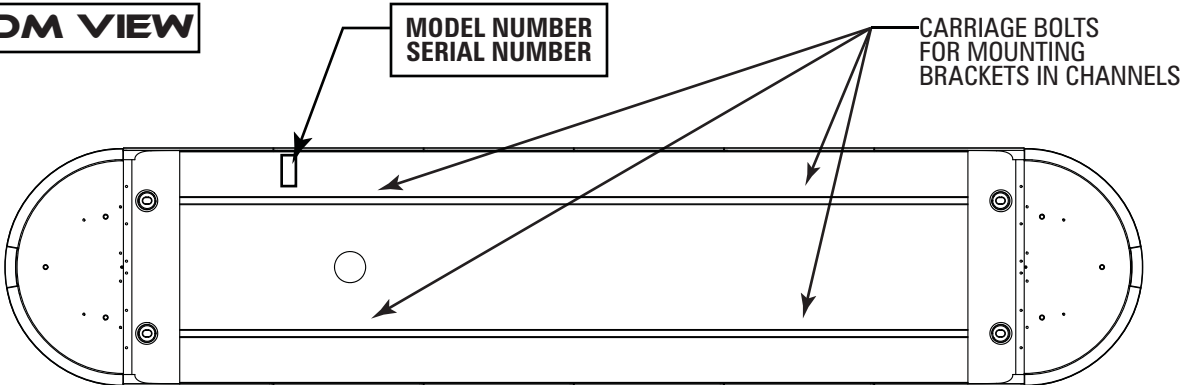

FIXED HEIGHT BRACKETS AND HOOK MOUNTING

1. Mount fixed height brackets (See Figure 1) using supplied (3) T25 torx screws on each side. Temporarily place the lightbar in it's correct position on the roof of the vehicle. The bar should be positioned about the center line of the "B" pillar.
2. Based on the bar's position, determine wire entry into vehicle. Mark location for later use. Note: Take into consideration the location of any structural, airbag, or heating and cooling system components that can be in the way of the the wire entry point or wire routing.
3. Install supplied vehicle specific hook brackets using supplied 1/4"-20 x 2.5 Hex Head bolts and Nylon Locking Nuts onto the bar mounting foot as shown in Figure 2. Nut will nest into molded socket to prevent turning and improve ease of installation. It's recommended that you position the nut into the foot and tap it slightly with a hammer to seat it into the cast foot prior to placing the bar on the roof. This will make installation easier.
4. Adjust fixed height bracket position on the Lightbar by loosening the (3) T25 Torx Screws on each side (See Figure 1). Be sure that there is enough clearance between fixed height brackets and vehicle specific brackets to allow for tensioning to roof. When the correct position is found, tighten T25 torx screws that attach fixed height bracket to lightbar base end plates.
5. Using the vehicle specific hook brackets as a template, drill 4 pilot holes using a #30 (.128 dia.) drill bit on each side of the vehicle.

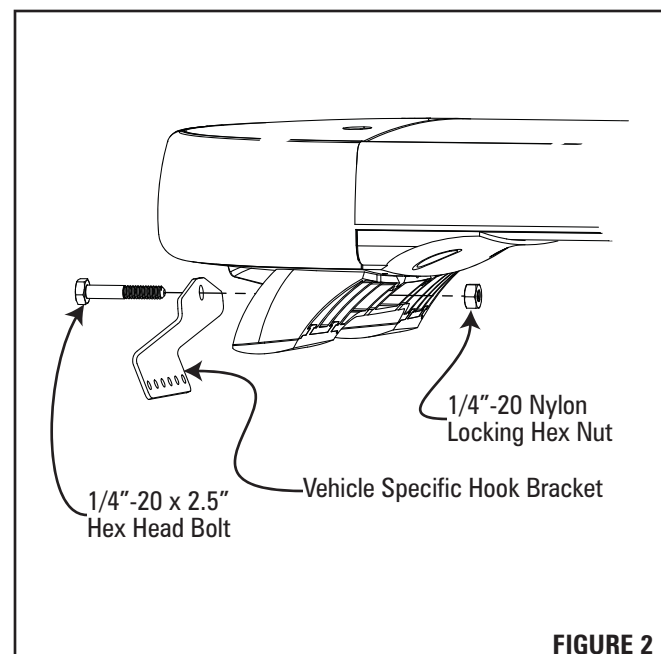
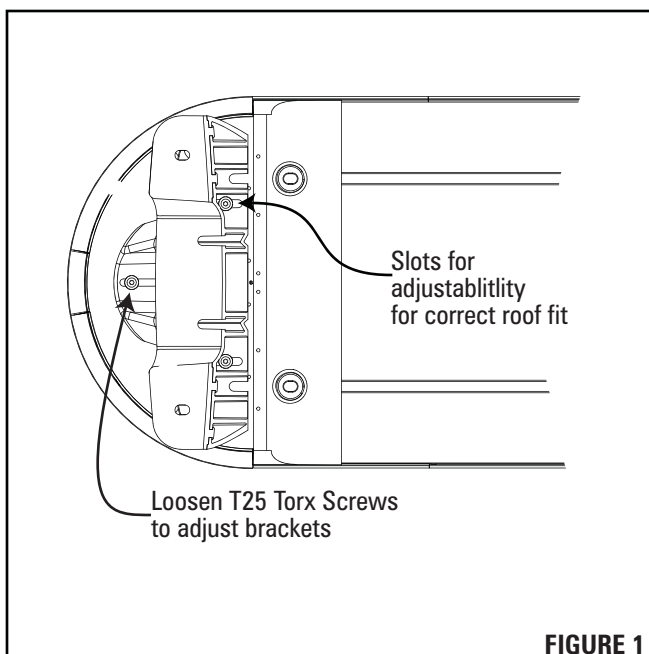

6. Secure each vehicle specific hook bracket by using the 8 supplied #8 x 1/2" Truss Head Sheet metal screws on each side.
7. Tighten each vehicle specific hook bracket by turning the 1/4"-20 x 2.5 Hex head bolt clockwise until bar is snug and no side to side or fore to aft movement occurs.
8. Route cables into vehicle. Use supplied rubber grommet in roof for sealing/protection of wires. It is recommended that silicone be placed around grommet to ensure roof sealing.

WARNING - ROUTE WIRES ONLY IN LOCATIONS THAT ARE NOT SUBJECTED TO POTENTIAL WEAR. MAKE SURE TO AVOID ROUTING WIRES IN THE DEPLOYMENT AREA OF YOUR AIR BAG. REFER TO YOUR VEHICLE'S OWNER'S MANUAL FOR AIR BAG DEPLOYMENT ZONES.

FIXED HEIGHT BRACKETS PERMANENT MOUNTING

1. Locate the permanent hardware kit that is included. Kit will include (4) 1/4"-20 x 1" hex head screws, (4) flat washers, (4) lock washers, (4) square nuts, and (6) T25 Torx Screws.
2. Attach fixed height brackets to lightbar using T25 Torx Screws. Brackets should be adjusted to identical positions at both ends of lightbar. See Figure 1.
3. Position the lightbar on the vehicle roof in the desired mounting location. The recommended location is directly above the B-Pillars. This is the strongest part of the roof. Make sure that the bar is centered on the vehicle left to right. Adjust bracket location on lightbar base end castings if needed.
4. Mark the location for the (4) holes that need to be drilled through the roof that will attach the fixed height brackets to the roof.
5. Determine the best location for cable entry depending on the configuration of your bar. Using a 1-1/4" hole saw, drill hole in the marked location. Be mindful that you do not drill through any roof support members or the interior headliner.
6. Using a 5/16" drill bit, drill the 4 holes in the locations that you marked in step 4. Clean and debur each hole.
7. Attach the lightbar to the vehicle using the supplied hardware. Use (1) flat washer and locking nut for each bolt. You should have a total of 4 bolts attaching the lightbar to the roof of the vehicle. See Figure 2 for details. It is recommended that you add silicone around the hole to ensure roof sealing.
8. Route cables into vehicle. Use supplied rubber grommet in roof for the sealing/protection of wires. It is recommended that silicone be placed around the grommet to ensure roof sealing.

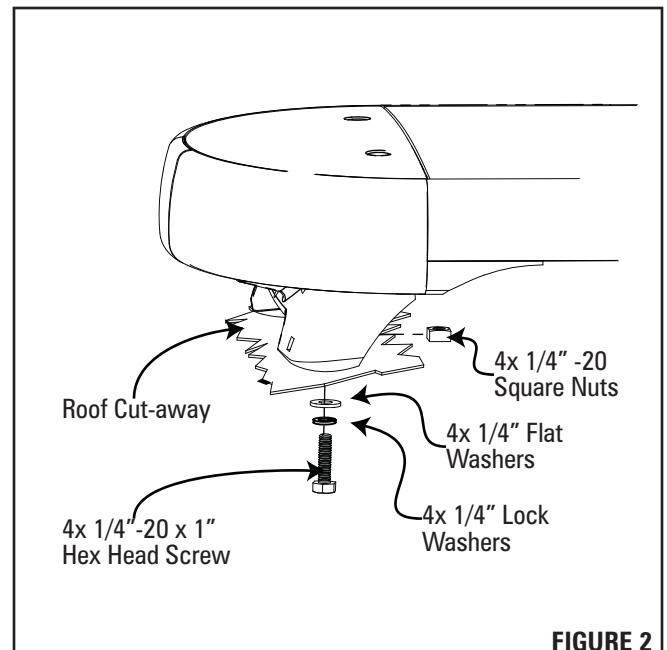
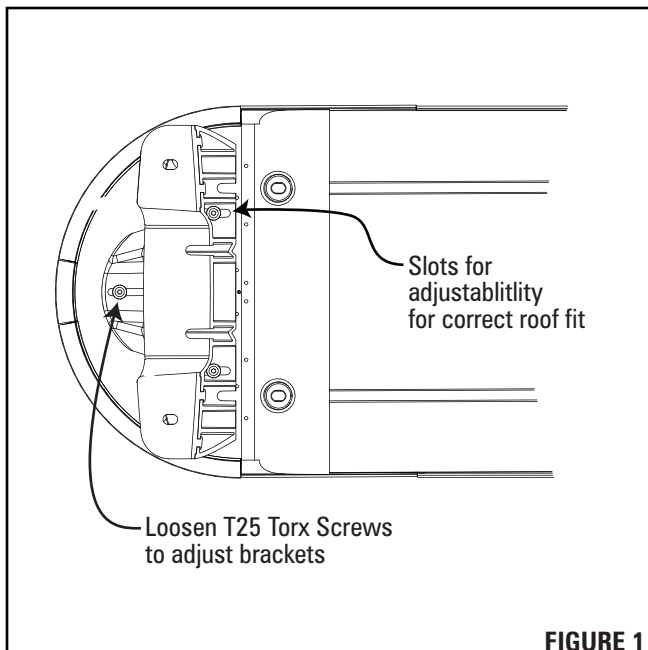

WARNING - ROUTE WIRES ONLY IN LOCATIONS THAT ARE NOT SUBJECTED TO POTENTIAL WEAR. MAKE SURE TO AVOID ROUTING WIRES IN THE DEPLOYMENT AREA OF YOUR AIR BAG. REFER TO YOUR VEHICLE'S OWNER'S MANUAL FOR AIR BAG DEPLOYMENT ZONES.

ADJUSTABLE HEIGHT BRACKETS AND HOOK MOUNTING

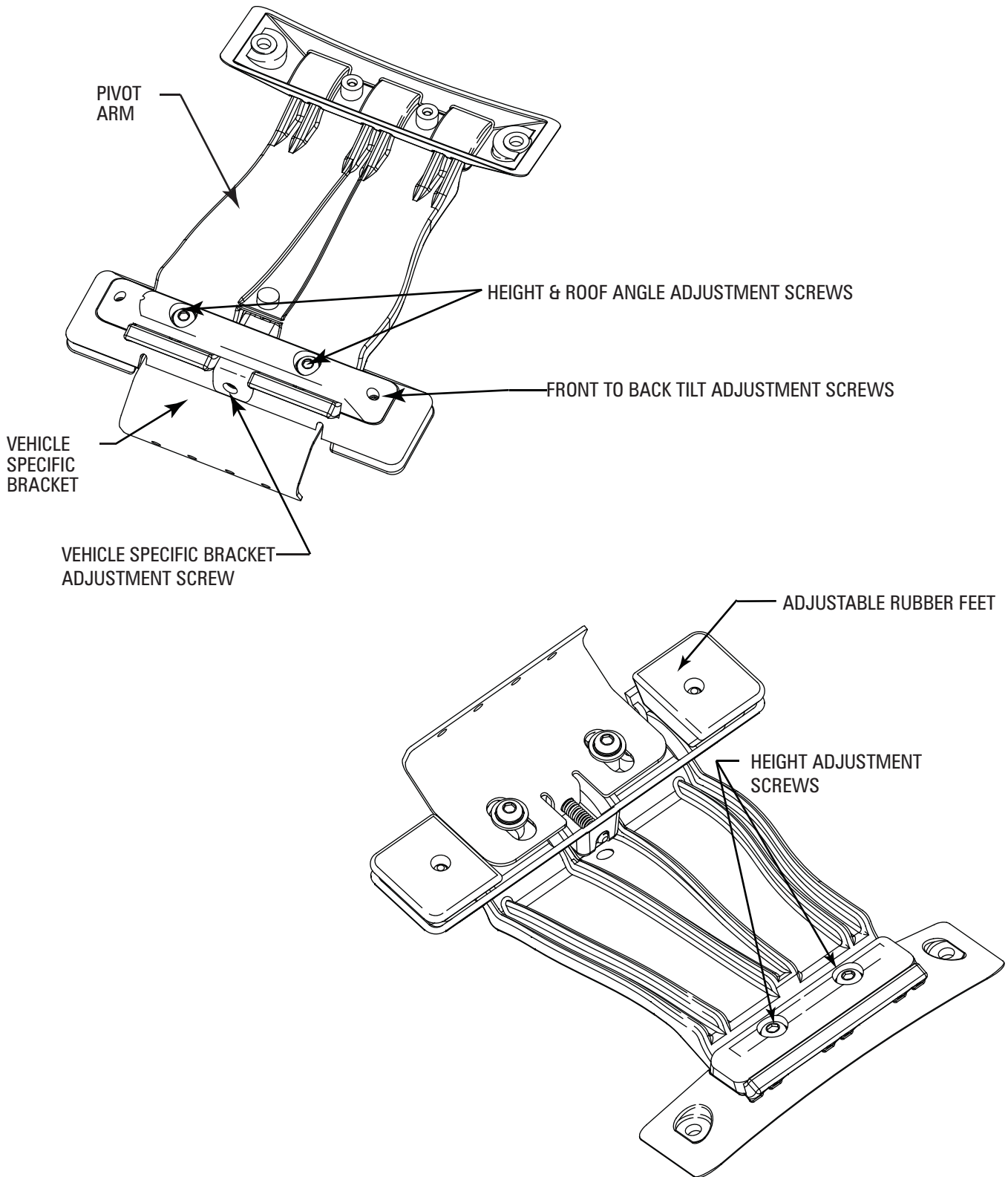

ADJUSTABLE HEIGHT BRACKETS AND HOOK MOUNTING

1. Attach vehicle specific bracket to adjustable mounting bracket. 1 1/2" Allen drive screw must be placed "underneath" adjustable mounting bracket (See Figure 1). Allen drive screw will be accessible through hole in front of adjustable bracket. Square nut must be placed in front of vehicle specific bracket. Place 1/4" lockwasher between square nut and vehicle specific hook bracket. See Figure 1 for details. To hold bracket in place, use provided hardware: 1 flat washer, 1 lock washer and 3/8" Allen drive screw per slot (as shown in Figure 1).
2. Attach mounting brackets to bar using the carriage bolts pre-installed on the bar. Use two lockwashers and an acorn nut per bolt. Leave acorn nuts loose so that the bracket has the ability to slide to fit your specific vehicle application. When choosing the placement for the mounting bracket, consider the cable routing and the risk of pinching wires or anything that can lead to cable failure. See Figure 2 for details.

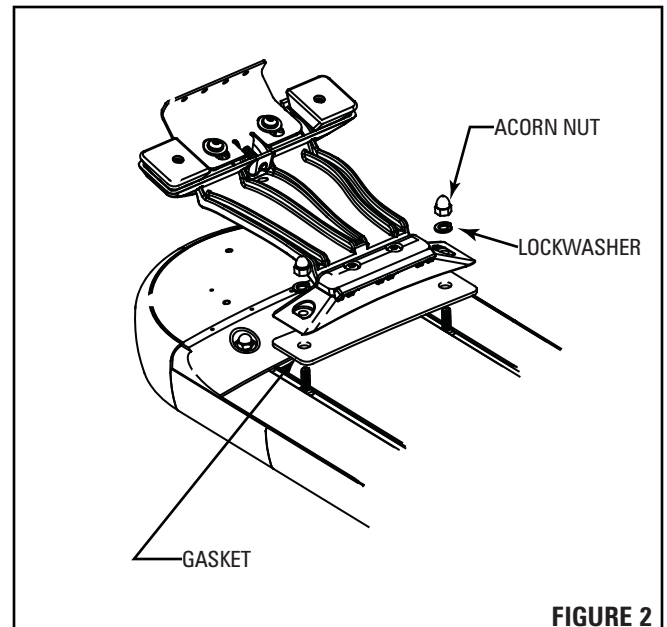
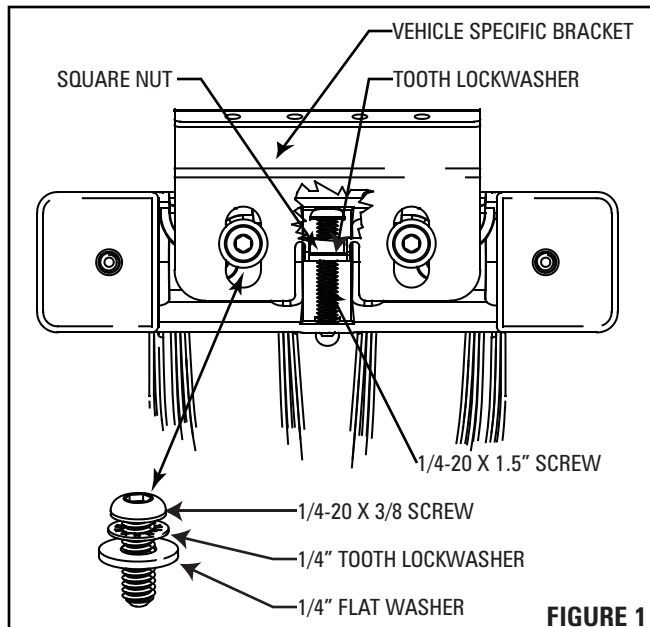

3. Position bar on roof about center line of "B" pillar. Determine final location of adjustable mounting brackets for vehicle application and ensure bar is centered about brackets and vehicle. Determine and mark off locations for mounting screws through vehicle specific bracket into roof. Determine location for wire entry into vehicle.
4. Determine the height of bar in relationship to the roof that best suits your application. Height of bar can be adjusted by loosening 4 allen drive screws that fasten pivot arm to either end. To simplify this procedure we recommend cutting 2 wood blocks to your preferred height to set gap height between roof and bar. Also be sure that adjustable height bracket feet are sitting flat on vehicle roof. See Figure 3.
5. After position of bar is determined. Tighten tilt and height adjustment screws (shown on page 5). Also tighten acorn nuts attaching adjustable mounting bracket to bar.
6. Drill 4 holes using a #30 (.128 dia.) drill bit on each side of vehicle that were marked in Step 5. Be careful not to damage weather stripping on vehicle.
7. Using 1 1/4" hole saw, drill hole in marked location on roof for cable routing. Be mindful that you do not drill through any roof support members or interior head liner. Clean and debur hole.
8. Secure each vehicle specific bracket by using 4 supplied #8 x 1/2" truss head screws.
9. When required, adjust front to back tilt to make bar parallel with road for best optical range. 5/32" allen drive adjustment screws are located above each mounting foot in the mounting bracket base. Adjustment screws must be turned counter-clockwise to raise either front or back of bar.

ELECTRICAL INSTALLATION

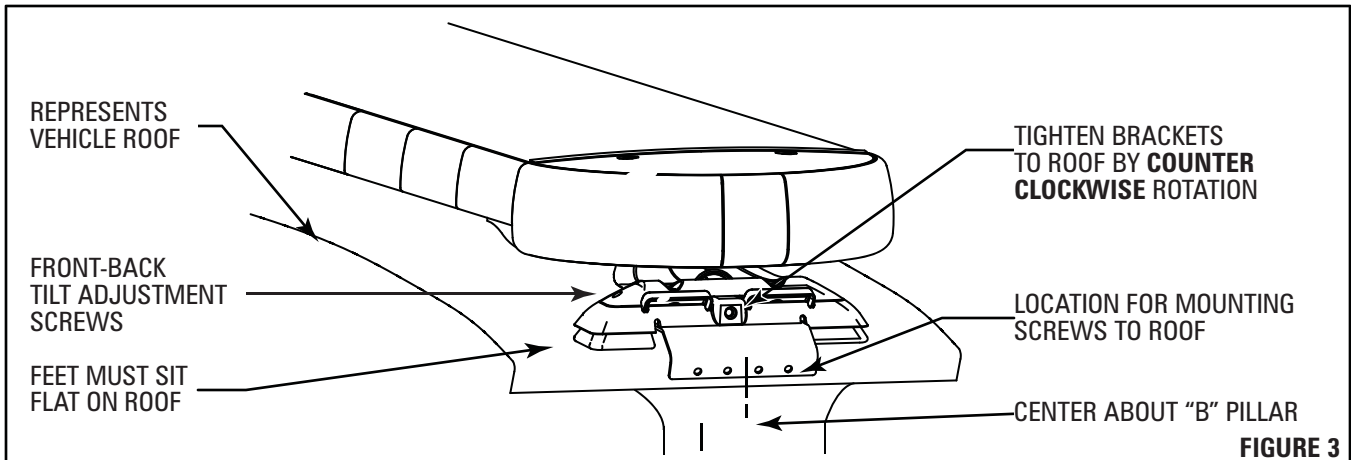

WARNING - CARE MUST BE TAKEN WHEN DRILLING THROUGH THE ROOF OF THE VEHICLE NOT TO DRILL INTO ANY EXISTING WIRING AND NOT TO DRILL THROUGH THE HEADLINER OR SUPPORT MEMBERS OF THE VEHICLE. CHECK BOTH SIDES OF THE MOUNTING SERVICE PRIOR TO DRILLING. DE-BURR ANY HOLES AND REMOVE ANY METAL SHARDS OR REMNANTS. INSTALL GROMMETS INTO ALL WIRE PASSAGE HOLES.

10. Tighten vehicle attachment brackets to roof by turning 5/32" Allen driver in **COUNTER-CLOCKWISE ROTATION**. Depending on your desired height, you may need to cut down your allen wrench to fit between the bar and the mounting bracket. Or use a micro drive gear wrench and 1/4" shank with 5/32" allen bit.

WARNING - ROUTE WIRES ONLY IN LOCATIONS THAT ARE NOT SUBJECTED TO POTENTIAL WEAR. MAKE SURE TO AVOID ROUTING WIRES IN THE DEPLOYMENT AREA OF YOUR AIR BAG. REFER TO YOUR VEHICLE OWNER'S MANUAL FOR AIR BAG DEPLOYMENT ZONES

11. Route cables into vehicle. Use supplied rubber grommet in roof for sealing/protection of wires. It is recommended that silicone be placed around grommet to ensure roof sealing.

12. Route cable down through the "B" pillar and towards switch panel. Refer to the instructions included with your switch for switch wiring information.

ELECTRICAL INSTALLATION

Featured Highlights:

Mode Select: The PINNACLE Lightbar is equipped with 2 selectable pattern configuration modes via the Mode Select Input. Default is Mode 1 where the input is floating, Mode 2 is in use when the input activated. This feature allows 2 complete sets of patterns to be programmed into the Lightbar's non-volatile memory. Once programming configuration is complete, the Mode can be changed "on-the-fly" by an activation switch.

Cruise Mode: Allows the user to program any Light Head Group(s) to "Glow" when this feature is activated.

Directional Arrow Built-in: If the lightbar was purchased with a directional arrow, the directional controller is built-in w/ 4 arrow patterns for each direction and 9 warning patterns for warning functions.

WARNING - ALL CUSTOMER SUPPLIED POWER WIRES CONNECTING TO THE POSITIVE (+) OR NEGATIVE (-) BATTERY TERMINAL OR LOCAL CHASSIS GROUND (-) MUST BE SIZED TO SUPPLY AT LEAST 125% OF THE MAXIMUM CURRENT AND PROPERLY FUSED AT THE POWER SOURCE WITH APPROPRIATELY RATED FUSE.

Power Cable:

1. Route lightbar power cables as close to vehicles power source (battery) as possible.

ELECTRICAL INSTALLATION

IMPORTANT: When passing cables through firewall or other sheet metal, insert grommet to protect the cable!

2. Install a 40Amp Fuse (customer supplied) to the end of the RED wire of the Lightbar Power Cable.
 - a. Remove the fuse before connecting any wires to the battery.
 - b. DO NOT USE CIRCUIT BREAKER OR FUSIBLE LINK.
3. Connect the other end of the Fuse to the POSITIVE (+) terminal of the battery.
 - a. Do NOT use any more than 2ft of wire between the battery terminal and the fuse and ensure the wire is protected and secured from being cut into; this is non-fused wire.
4. Connect the BLACK wire to the factory chassis ground right next to the battery.

Control (Data) Cable:

1. Route Lightbar Control Cable to the location where all controlling equipment will be, i.e. switch box, center console area.
2. Locate the Breakout Box in the same area to connect jumpers from the switching equipment to the breakout box.

NOTE: Power is supplied to Breakout Box through data cable, no additional power connections necessary.

Initial Power up Test:

1. Insert 40Amp Fuse into Fuse Holder.
2. Plug data jack into Data 1 connector of the breakout box (Data 2 may also be used, but is for future use.)
3. Observe the GREEN Data Link indicator LED on the Breakout Box; the LED will turn steady ON about 15 seconds after main power is connected
4. When GREEN LED is steady ON (see below), the lightbar is ready to be configured.

Low Power (Standby) Mode

If there is no input to the breakout box for 15 seconds, the lightbar will go into a "standby" mode. The standby mode is a low power mode that is used to extend the life of your battery. The green light will turn off when the lightbar enters standby mode. The red light will flash every five seconds showing that it has power. The lightbar will awaken from the standby mode if any input is activated on the breakout box.

*note in standby mode each switch in the down position will contribute to another 0.03A of standby current.

Pattern Selection:

- a. First review the Pattern Table (included on pg. 12) before attempting pattern selection to familiarize yourself with patterns available for the different Functions
 - i. Depending on the Lightbar configuration purchased, the Arrow Pattern Table may or may not be applicable.
- b. Select the Input Function(s) and apply +12V to activate.
 - i. To change patterns on more than one input function, simply connect desired input functions together. Before doing this, make sure all the inputs are using the same pattern table and are on the same pattern to make pattern identification easier.
- c. Momentarily apply +12V to advance to the next pattern. See Flash Pattern Table below.
 - i. Once the last pattern is reached, the next pattern advance will cycle back to Pattern #1.
- d. Once the desired pattern is reached, simply disconnect the Input Function(s) and proceed to the next Input Function(s) to be configured.
 - i. The pattern is saved in non-volatile memory every time it is advanced.

Mode Configuration: See Mode Input on Function Description Table (attached sheet) for more details about this feature.

- a. Mode 1 (Default): the Mode Select Input will be floating (no-connection)
 - i. Continue on to Pattern Selection instructions below to set the patterns for this Mode
- b. Mode 2: apply +12V to activate Mode 2. This will need to be activated to configure the Lightbar in Mode 2
 - i. Continue on to Pattern Selection instructions below to set the patterns for this Mode
 - ii. Once patterns have been setup, connect Mode Select Input to switching system.
 - iii. When the Mode Select Input is activated, the Mode 2 Patterns will flash.

Cruise Mode Configuration: See Cruise Mode Input on Function Description Table (attached sheet) for more details about this Feature.

- a. Apply +12V to activate Cruise Mode for configuration setup.
- b. Determine what Input Function(s) are desired to use Cruise Mode.
- c. Apply +12V to the Input Function(s) desired.
 - i. NOTE: Lights will flash preset flash pattern
- d. With both the Cruise Mode Input and the Input Function(s) activated, momentarily apply +12V to the pattern select wire to toggle the Cruise Mode to ON (default is OFF).
- e. Observe the OFF sequence of the flash pattern is ON dim.
- f. Disconnect the Input Function wire(s) (while leaving cruise mode input active) and observe the lightbar is NOT flashing, but the output function(s) recently set are glowing steady.

BREAKOUT BOX

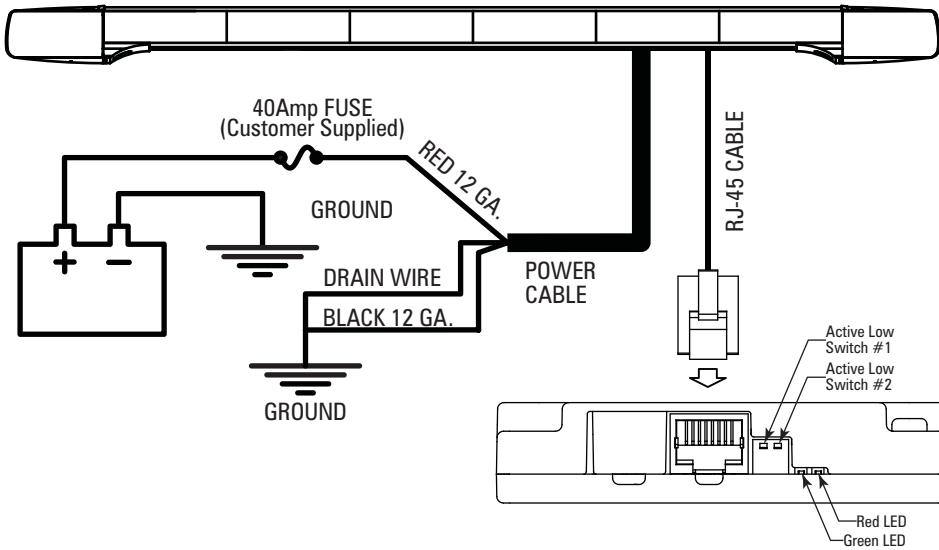

RED LIGHT

No Inputs Flashes Every 5 Secs.
Input Activated Steady On
Added Input Brief Flash

GREEN LIGHT

Command Rec'd Steady On Has good
(See below) connection

LOW POWER (STANDBY) MODE

If there is no input to the breakout box for 15 seconds, the lightbar will go into a "standby" mode. The standby mode is a low power mode that is used to extend the life of your battery. The green light will turn off when the lightbar enters standby mode. The red light will flash every five seconds showing that it has power. The lightbar will awaken from the standby mode if any input is activated on the breakout box.

*note in standby mode each switch in the down position will contribute to another 0.03A of standby current.

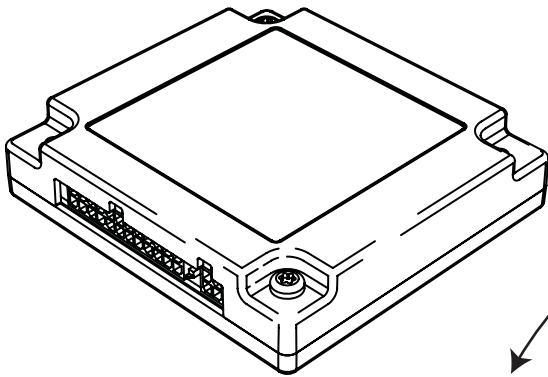

- When the switch is in the up position inputs connected to that switch are active high. To activate an active high input, apply 12Vdc.
- When the switch is in the down position inputs connected to that switch are active low. To activate the active low, apply ground (negative).

Functional Inputs
Functional inputs connect to your control head or switching unit. Applying +12Vdc to any functional input will activate it's function (default-active high). For more information, see switches explanation on second page.

Wire Color (Major Color/Stripe)	Pin#	Standard Functions (4 Wire Arrow Control)	Discrete Functions (8 Wire Arrow Control)
Light Green/White	24	Left Turn Signal*	Discrete Output #4*
Red/Black	23	Right Turn Signal*	Discrete Output #3*
Orange/White	22	Rear Inboard 3	Discrete Output #2*
Yellow/White	21	Rear Inboard 2	Discrete Output #1 (L)*
Brown	20	Front Takedown	Front Takedown
Red/White	19	Alley Flash	Alley Flash
Pink	18	Alley Driver	Alley Driver
Red	17	Alley Passenger	Alley Passenger
Orange	16	Front Inboard 3	Front Inboard 3
Yellow	15	Front Inboard 2	Front Inboard 2
Green	14	Front Inboard 1	Front Inboard 1
Blue	13	Front Corners	Front Corners
Pink/White	12	Arrow, Left*	Discrete Output #8 (R)*
Purple/White	11	Arrow, Center*	Discrete Output #7*
Gray/White	10	Arrow, Right*	Discrete Output #6*
Black/White	9	Arrow, Warning	Discrete Output #5*
White	8	Pattern Select*	Pattern Select*
Purple	7	Low Power	Low Power
Brown/White	6	Front Takedown Flash	Front Takedown Flash
Light Green	5	Auxiliary*	Auxiliary*
Black	4	Cruise Lights*	Cruise Lights*
Gray	3	Mode Select*	Mode Select*
Green/White	2	Rear Inboard 1	Rear Inboard 1
Blue/White	1	Rear Corners	Rear Corners

* - Reference page 11 for detailed explanation of functions

Note - Reference Switch table for explanation of what inputs are affected by Active Low Switches

Connector Pinning Chart

24	23	22	21	20	19	18	17	16	15	14	13
12	11	10	9	8	7	6	5	4	3	2	1

- Controlled by Active Low Switch #2
- Controlled by Active Low Switch #1

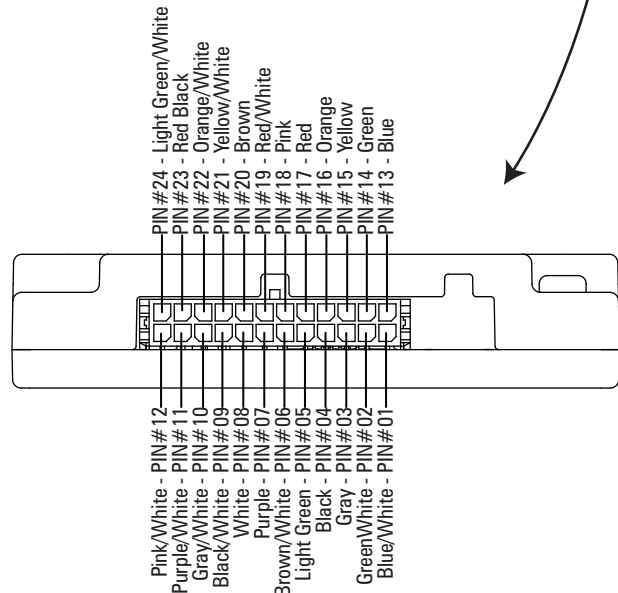

FLASH PATTERNS AND CONNECTOR INSTRUCTIONS

FLASH PATTERN TABLE

BREAKOUT BOX HOOKUP:

Make sure the 24-pin connector and the RJ-45 connector are snapped in securely.

Follow the label for the wire color to connect to a 12Vdc source, which turns on that given light or lights.

Make sure your wire connections are secured and isolated from any other wire.

LED Module Flash Patterns

#	Pattern Name	Sequence	fpm*	fps**
1	Quint	Alternating	70	1.18
2	Warp	Alternating	350	5.88
3	Inter-Cycle Flash	Alternating	-	-
4	Quad Flash	Alternating	80	1.35
5	RoadRunner™	Alternating	115	1.92
6	RoadRunner™	Simultaneous	115	1.92
7	Slow Runner	Alternating	70	1.16
8	Slow Runner	Simultaneous	70	1.16
9	Q-Switch™	Variable	-	-
10	Single, Steady Burn	Steady Burn	115	1.92
11	Quad, Steady Burn	Steady Burn	80	1.35
12	Warp, Steady Burn	Steady Burn	350	5.88
13	Nothing, Steady Burn	Steady Burn	-	-
14	E-Pattern Single Flash	Alternating	230	3.85
15	E-Pattern Double Flash	Alternating	128	2.13
16	E-Pattern Single Flash	Simultaneous	230	3.85
17	E-Pattern Double Flash	Simultaneous	155	2.6
18	Steady Burn	Steady Burn	-	-
19	Warp 1,2,3	Variable	-	-
20	Warp 2,3,1	Variable	-	-
21	Warp 3,2,1	Variable	-	-

*fpm=Flashes per Minute

**fps=Flashes per Second

LED Takedown & Alley Flash Patterns

1	RoadRunner™	Alternating	115	1.92
2	PowerPulse™	Alternating	180	3.00
3	Q-Switch™	Variable	-	-
4	ETM™	Simultaneous	214	3.57
5	Steady Burn	Steady Burn	-	-

Directional Bar Warning Function Patterns

1	PowerPulse™ Alternating	Center Out	180	3.00
2	PowerPulse™ Alternating	Left/Right	180	3.00
3	Quad Alternating	Center Out	80	1.35
4	Warp Alternating	Adjacent	350	5.88
5		2X Individual Sweep	-	-
6	Hyper Scan	Pulsing + Sweep	-	-
7	Super Scan	Dual Rate Pulse/Alt	-	-
8	Power Flash	Dual Rate Alt/Pulse	-	-
9	Thunder and Lightning	Random	-	-

Split Arrow Bars Also Have The Following Multi-color Patterns

10	RoadRunner™	Alternating	115	1.92
11	Warp	Adjacent	350	5.88
12	Warp	Adjacent	350	5.88
13	Inter-Cycle Flash	Adjacent	-	-
14	Inter-Cycle Flash	Alternating	-	-
15	Inter-Cycle Flash	Alternating	-	-
16	Inter-Cycle Flash	Alternating	-	-
17	Inter-Cycle Flash	Alternating	-	-

Directional Bar Directional Function Patterns For Left, Center Out, & Right Sequences

1	Solid Arrow Plus, Slow	Grow / Decay
2	Solid Arrow, Slow	Solid
3	Individual Arrow, Fast	Individual
4	Chaser Arrow, Fast	2X Individual

LIGHTBAR CONTROLLER CONNECTOR INSTRUCTIONS

Input Group Control	Light Output Groups
Front Corners	Orange
Rear Corners	Brown
Front Inboard 1	Red and Yellow
Front Inboard 2	Green
Front Inboard 3	Blue
Rear Inboard 1	Red and Yellow (2-wire)
Rear Inboard 2	Green (2-wire)
Rear Inboard 3	Blue (2-wire)
Front Takedown Flash	White
Alley Flash	Small Connector

EPL 9000 SWITCH SETTINGS						PURPOSE
SW1	SW2	SW3	SW4	SW5	SW6	
Off	Off	Off				8-WIRE CONTROL
Off	Off	On				NO ARROW
Off	On	Off				N/A
Off	On	On				4 MOD ARROW
On	Off	Off				5 MOD ARROW
On	Off	On				6 MOD ARROW
On	On	Off				7 MOD ARROW
On	On	On				8 MOD ARROW
			On			PASSENGER-SIDE EXIT
			Off			DRIVER-SIDE EXIT
				On		SPLIT-COLOR ARROW MODULES
				Off		FULL ARROW MODULE
					On	FOR TURN SIGNALS ON YELLOW OUTPUT
					Off	FOR TURN SIGNALS ON BLUE OUTPUT

CONTROLLER AND WIRE HARNESS INSTRUCTIONS

LIGHT MODULE WIRE HARNESS LOCATIONS

REPLACEMENT OF INBOARD, CORNER, TAKEDOWN AND ALLEY LED MODULES:

1. Disconnect main power.
2. Remove top cover by removing 6 sealed torx head screws.
3. Locate module and remove mounting screw. Pull module from lightbar.
4. Remove connector from rear of module by disengaging locking latch and pull connector from back of module. (see illustration at right)
5. Push module connector into module ensuring locking latch is seated properly.
6. Replace module and 2 screws that fasten module to base extrusion.
7. Restore power to bar and test new module to ensure functionality.
8. Replace top cover of bar with screws removed in step 2.

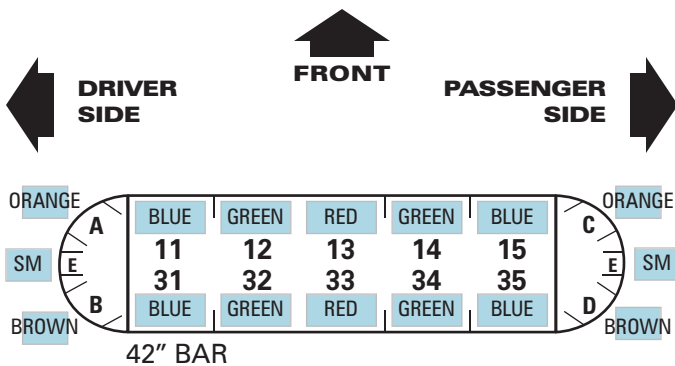
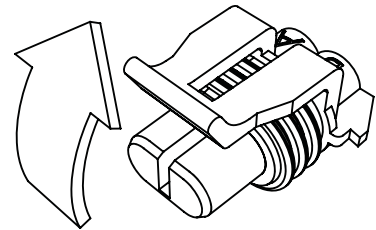

Colors shown indicate color coded labels on wiring harness.

White is used for all Take Down lights. Replace color indicated on diagram with white labeled wire.

SM=Small connector used on Alley lights only.

If modules are being replaced in the field make sure they are reinstalled with single wire connectors to FRONT of vehicle. See below.

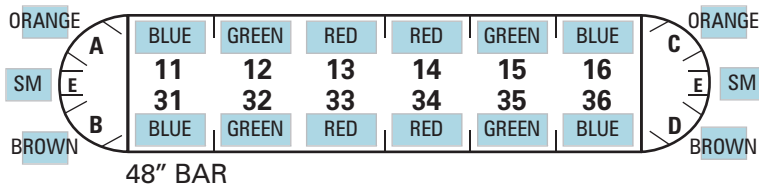

Red, Blue Double Wire (Rear)

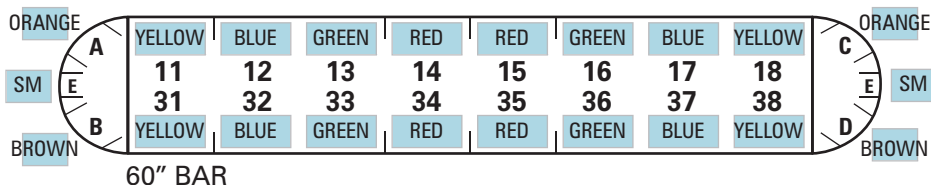
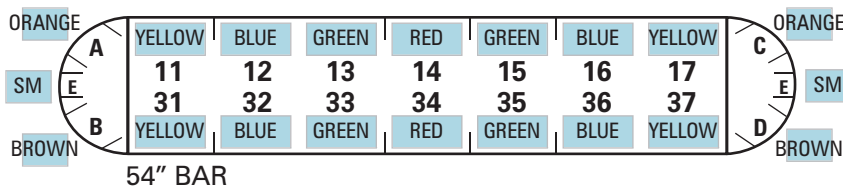
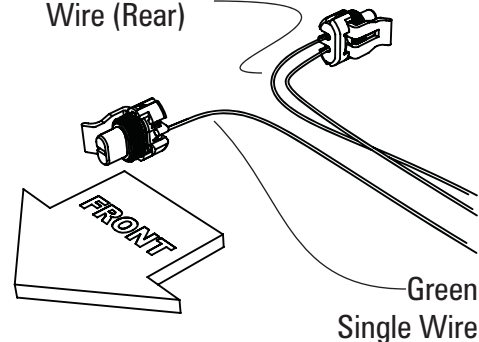

PINNACLE TROUBLESHOOTING

NORMAL OPERATION

Under Normal operation with lightbar turned on the breakout box will have the Green and Red LED light on steady. When ever you change an input to the lightbar the Red LED on the breakout box will flash then go back to steady.

When the lightbar is off (no inputs active) the Green LED on the breakout box will stay on for 15 seconds then go off putting the lightbar into sleep (standby) mode. The Red LED will flash every 5 seconds to tell you there is power to the breakout box and it is waiting for an input to turn on the lightbar.

NO OPERATION

- | | |
|---|---|
| No LED on or flashing on Breakout box; | Check input power and ground to lightbar, check data cable for damage and/or opens, check 5 amp fuse in electronic control box in lightbar. |
| Breakout box LED's operating correctly; | Check FH1 & FH2 fuse in electronic control box in lightbar |

NO OR INCORRECT INBOARDS OR CORNERS LIGHTS (WARNING)

- | | |
|---|--|
| Breakout box LED's operating correctly; | Check FH1 fuse in electronic control box in lightbar |
| No steady Red LED on breakout box; | Check 24-pin connector at breakout box (insure it is snapped in correctly), check appropriate input to breakout box for output lights which should be on |
| No rear warning lights; | Check dip switch SW5 setting for full (off) or split (on) arrow (on full you may not get any warning) (after arrow dip switch changes main power must be cycled) |

NO TAKEDOWNS OR ALLEYS LIGHTS

- | | |
|---|---|
| Breakout box LED's operating correctly; | Check FH2 fuse in electronic control box in lightbar |
| No steady Red LED on breakout box; | Check 24-pin connector at breakout box (insure it is snapped in correctly), check appropriate input to breakout box for output lights which should be on |

INCORRECT OR NO ARROW OPERATION

- | | |
|---|--|
| Breakout box LED's operating correctly; | Check dip switches setting in electronic control box in lightbar (after arrow dip switch changes main power must be cycled) |
| No steady Red LED on breakout box; | Check 24-pin connector at breakout box (insure it is snapped in correctly), check appropriate input to breakout box for output lights which should be on |
| Arrow direction incorrect; | Change passenger/drivers side dip switch SW4 in electronic control box in lightbar (after arrow dip switch changes main power must be cycled) |
| 8-wire control not operating; | Check dip switch setting SW1-3 (should be off, off, off) in electronic control box in lightbar (after arrow dip switch changes main power must be cycled) |
| Split arrow not operating; | Check dip switch SW5 (should be on) in electronic control box in lightbar (after arrow dip switch changes main power must be cycled) |

REPLACEMENT PARTS

STANDARD REPLACEMENT PARTS

EPL PART #	DESCRIPTION
PEPL9A0C	Pinnacle Blank Alley Light - Clear Lens/No LEDs
PEPL9A1C-D	Pinnacle Alley Light, 15° Forward Facing, Driver Side - Clear Lens/White LEDs
PEPL9A1C-P	Pinnacle Alley Light, 15° Forward Facing, Passenger Side - Clear Lens/White LEDs
PEPL9A2C	Pinnacle Alley Light, Standard - Clear Lens/White LEDs
PEPL9BBHNS	Pinnacle Breakout Box Harness, 12" Length
PEPL9BBHNL	Pinnacle Breakout Box Harness, 36" Length
PEPL9CNTRL1	Pinnacle Motherboard, 12 volt
PEPL9CS12AA	Pinnacle Corner Module - Amber Lens/Amber LEDs
PEPL9CS12AC	Pinnacle Corner Module - Clear Lens/Amber LEDs
PEPL9CS12BB	Pinnacle Corner Module - Blue Lens/Blue LEDs
PEPL9CS12BC	Pinnacle Corner Module - Clear Lens/Blue LEDs
PEPL9CS12GC	Pinnacle Corner Module - Clear Lens/Green LEDs
PEPL9CS12RC	Pinnacle Corner Module - Clear Lens/Red LEDs
PEPL9CS12RR	Pinnacle Corner Module - Red Lens/Red LEDs
PEPL9CS12WC	Pinnacle Corner Module - Clear Lens/White LEDs
PEPL9HL6C	Pinnacle Takedown/Work Light Module - Clear Lens/White LEDs
PEPL9L00A	Pinnacle Blank Inboard Module - Amber Lens/ No LEDs
PEPL9L00B	Pinnacle Blank Inboard Module - Blue Lens/ No LEDs
PEPL9L00C	Pinnacle Blank Inboard Module - Clear Lens/ No LEDs
PEPL9L00R	Pinnacle Blank Inboard Module - Red Lens/ No LEDs
PEPL9LLSAA	Pinnacle Inboard Module - Amber Lens/Amber LEDs
PEPL9LLSAC	Pinnacle Inboard Module - Clear Lens/Amber LEDs
PEPL9LLSBB	Pinnacle Inboard Module - Blue Lens/Blue LEDs
PEPL9LLSBC	Pinnacle Inboard Module - Clear Lens/Blue LEDs
PEPL9LLSGC	Pinnacle Inboard Module - Clear Lens/Green LEDs
PEPL9LLSRC	Pinnacle Inboard Module - Clear Lens/Red LEDs
PEPL9LLSRR	Pinnacle Inboard Module - Red Lens/Red LEDs
PEPL9LLSWC	Pinnacle Inboard Module - Clear Lens/White LEDs
PEPL9LLSFC	Pinnacle Dual Color Arrow Module, Clear Lens – White/Amber
PEPL9LLSKC	Pinnacle Dual Color Arrow Module, Clear Lens – Red/Amber
PEPL9LLSMC	Pinnacle Dual Color Arrow Module, Clear Lens – Blue/Amber
PEPL9LLSPC	Pinnacle Dual Color Arrow Module, Clear Lens – Green/Amber
PEPL9LLSZC	Pinnacle Dual Color Arrow Module, Clear Lens – No LEDs/Amber
PEPL9LLSJC	Pinnacle Dual Color Warning Module Clear Lens - Red/Blue
PEPL9LLSNC	Pinnacle Dual Color Warning Module Clear Lens - Blue/Green
PEPL9RFGR	Roof Wire Grommet for External Break Out Box on Pinnacle Lightbars
PETLJ00	External Breakout Box for ETL 5000 & Pinnacle Lightbars
PETLK00	Adjustable Height Mounting Bracket (1 bracket) for use w/ ETL 5000 & Pinnacle Lightbars
PETLK04	Low Profile Fixed Height Mounting Bracket (1 bracket) for use w/ ETL 5000 & Pinnacle Lightbars
PETLMX1	Hook Kit Extension for use w/ Adjustable Height Bracket on ETL 5000 & Pinnacle Lightbars
PETLM00	Permanent Mount Hardware for the Adjustable Height Bracket for use w/ ETL 5000 & Pinnacle Lightbars
PETLM(nn)	Adjustable Height Bracket Hook Kit for ETL 5000 or Pinnacle Lightbars:*
PETLR00	Permanent Mount Hardware for the Low Profile Fixed Height Bracket for use w/ ETL 5000 & Pinnacle Lightbars

* SEE "HOOK KIT COMPATIBILITY CHART" FOR VEHICLE MODEL COMPATIBILITY

http://www.soundoffsignal.com/warnamber/lightbars/literature/HookKits_ETL5000.pdf

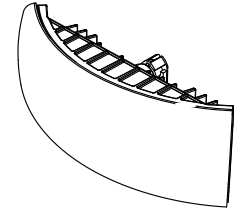

Corner LED Assembly

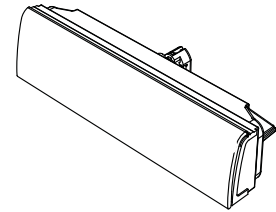

Inboard LED Assembly



Takedown/Worklight Assembly

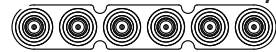

Alley Light Assembly

WARRANTY & RETURN GOODS PROCEDURE

To review our Limited Warranty Statement & Return Policy for this or any SoundOff Signal product please visit our website at www.soundoffsignal.com and select the "Warranty & Returns" link along the left column of our home page. If you have questions regarding this product please contact Technical Services, Monday - Friday, 8 am to 5 pm at 1.800.338.7337, press #4 to skip the automated message. Questions or comments that do not require immediate attention may be emailed to techsupport@soundoffsignal.com. 1.800.338.7337. / www.soundoffsignal.com / Thank you for trusting us with your safety!

Warranty Return Process

Please contact your SoundOff Signal Sales Representative, Customer Services staff or our Technical Department (800.338.7337) for a RMA# (Return Merchandise Authorization) number.

The following information is required for issuance of the RMA#:

- Reason for returning the product*
- Address where replacement product is to be shipped*
- Telephone number where you may be reached*
- SoundOff Signal invoice number on which product was purchased**
- SoundOff Signal part number and serial number**
- E-mail address where RMA# should be e-mailed**
- Fax number where RMA# should be faxed**

SoundOff Signal will NOT accept returns without an RMA#. Each RMA# is good for only one (1) item and will expire (7) days after the date it was issued. Products must be shipped back to SoundOff Signal and the RMA# clearly marked on the outside of the package near the shipping label. Please use the following address on your shipping label:

ATTN.: RMA#
SoundOff Signal
3900 Central Parkway
Hudsonville, MI 49426

Please see reverse side for manufacturer warranty.

Warranty Exclusions

Shipping & Handling, labor and service fees are non-refundable. SoundOff Signal is not liable for any damage due to installation or personal injury as a result of using SoundOff Signal product.

Warranty Forfeiture

Warranty will not be granted if the Warranty Return Policy & Procedure rules are not strictly followed. Physical damage resulting from customer abuse will void warranty. Warranty will also be voided if any SoundOff Signal and/or manufacturer serial tags, product stickers, seals, or the like, are removed, altered or tampered with. Returned product that is damaged by shipping via the RMA# procedure is not the responsibility of SoundOff Signal.

* RMA# will not be given without this information.

** If available, please provide this information.

Document effective date on cover and below supersedes previously dated policies and statements.

There are no other warranties, expressed or implied, including, but not limited to, any implied merchantability or fitness for a particular use. SoundOff Signal reserves the right to modify this warranty statement at any time; or to discontinue, modify, or upgrade any products of its manufacture with design improvements without prior notice.

ISO-9001 Registered ©2009 SoundOff Signal Emergency Technology Inc. dba SoundOff Signal
Printed in the USA / All Rights Reserved / Specifications subject to change without notice.
PO Box 206 / 3900 Central Parkway / Hudsonville, MI 49426
toll free 800.338.7337 / office 616.896.7100 / order fax 616.896.1286 / www.soundoffsignal.com