

# INSTALLATION & OPERATION MANUAL



## LSS222 Dual Stacked Beacon

Contents:

- Introduction.....2
- Features and Specifications.....2-3
- Flash Patterns.....3
- Dimensions.....3
- Current Draw.....4
- Installation & Mounting.....5
- Wiring.....5
- Operation.....6
- Maintenance.....6
- Troubleshooting .....6
- Notes.....6-7
- Warranty.....8

**IMPORTANT:** Read all instructions and warnings before installing and using.  
**INSTALLER:** This manual must be delivered to the end user of this equipment.

## Introduction

The LSS222 is a weatherproof LED based warning light beacon that contains 16 state-of-the-art high intensity LED's in two stacked rows. The reflector's unique design captures the light of the LED's with individual parabolas that efficiently collect the light and broadcast it through the fresnelled lens.

**WARNING!**



This Product contains high intensity LED devices. To prevent eye damage, DO NOT stare into light beam at close range.



**WARNING!**

The use of this or any warning device does not insure that all drivers can or will observe or react to an emergency warning signal. Never take the right-of-way for granted. It is your responsibility to be sure you can proceed safely before entering an intersection, driving against traffic, responding at a high rate of speed, or walking on or around traffic lanes.

The effectiveness of this warning device is highly dependent upon correct mounting and wiring. Read and follow the manufacturer's instructions before installing or using this device. The vehicle operator should insure daily that all features of the device operate correctly. In use, the vehicle operator should insure the projection of the warning signal is not blocked by vehicle components (i.e.: open trunks or compartment doors), people, vehicles, or other obstructions. This equipment is intended for use by authorized personnel only. It is the user's responsibility to understand and obey all laws regarding emergency warning devices. The user should check all applicable city, state and federal laws and regulations.

Code 3, Inc., assumes no liability for any loss resulting from the use of this warning device.

Proper installation is vital to the performance of this warning device and the safe operation of the emergency vehicle. It is important to recognize that the operator of the emergency vehicle is under psychological and physiological stress caused by the emergency situation. The warning device should be installed in such a manner as to: A) Not reduce the output performance of the system, B) Place the controls within convenient reach of the operator so that he can operate the system without losing eye contact with the roadway.

Emergency warning devices often require high electrical voltages and/or currents. Properly protect and use caution around live electrical connections. Grounding or shorting of electrical connections can cause high current arcing, which can cause personal injury and/or severe vehicle damage, including fire.

**PROPER INSTALLATION COMBINED WITH OPERATOR TRAINING IN THE PROPER USE OF EMERGENCY WARNING DEVICES IS ESSENTIAL TO INSURE THE SAFETY OF EMERGENCY PERSONNEL AND THE PUBLIC.**

## Features and Specifications

**Operating Voltage:** DC10V-30V, Reverse Polarity Protected

**Flash Modes:**

1. Cycle-Flash: Cycles through Triple, Quad, Double, and Fast Single modes at approximately 109 fpm.
2. Triple-Flash: Three consecutive pulses per flash.
3. Quad-Flash: Four consecutive pulses per flash.
4. Double-Flash: Two consecutive pulses per flash.
5. Fast Single: Single flash pattern.
6. Steady-burn: Continuous ON-state operation.

Please note that a PHASE 1 flash pattern alternates with other synchronized beacons and a PHASE 2 pattern flashes simultaneously with other synchronized beacons.

## Flash Patterns:

PATTERN NO.	PATTERNS	SYNCHRONIZE
1	75FPM Triple Alter Phase 1	YES
2	75FPM Triple Alter Phase 2	YES
3	75FPM Quad Flash Phase 1	YES
4	75FPM Quad Flash Phase 2	YES
5	Double Flash 75FPM Phase 1 CA T13	YES
6	Double Flash 75FPM Phase 2 CA T13	YES
7	Double Flash 150FPM Phase 1	YES
8	Double Flash 150FPM Phase 2	YES
9	Single Flash 75FPM Phase 1 CA T13	YES
10	Single Flash 75FPM Phase 2 CA T13	YES
11	Single Flash 150FPM Phase 1	YES
12	Single Flash 150FPM Phase 2	YES
13	Single Flash 375FPM Phase 1	YES
14	Single Flash 375FPM Phase 2	YES
15	Triple Alter D 75FPM	YES
16	Dynamic Flash D 150FPM	YES
17	Double Flash D 150FPM	YES
18	Double Flash D 75FPM	YES
19	Single Flash D 375FPM	YES
20	Single Flash D 150FPM	YES
21	Single Flash D 75FPM	YES
22	Dynamic Flash Phase 1	YES
23	Dynamic Flash Phase 2	YES
24	Modulation Action Flash	NO
25	Modulation Action Flash	NO
26	Rotator 50FPM	YES
27	Rotator 75FPM	YES
28	Rotator 125FPM	YES
29	Rotator 250FPM	YES
30	NFPA Quad Flash	NO
31	Single Flash 75FPM CA T13	NO
32	Double Flash 75 FPM CA T13	NO
33	ECE 65 Double Flash Phase 1	YES
34	ECE 65 Double Flash Phase 2	YES
35	ECE 65 120FPM Single Flash Phase 1	YES
36	ECE 65 120FPM Single Flash Phase 2	YES
37	ECE 65 125FPM Rotator Flash	YES
38	Steady Burn	NO
39	Autorun (random)	NO
40	OFF	

# Dimensions

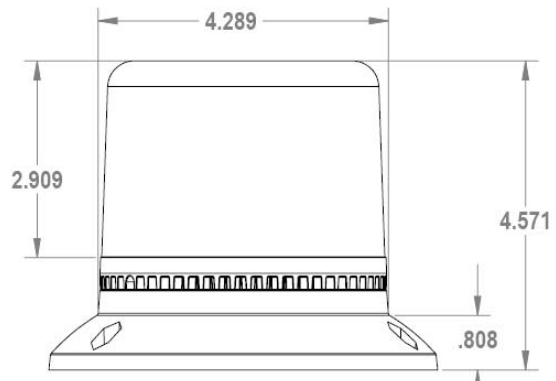

LS222 Pipe Mount / Permanent Mount

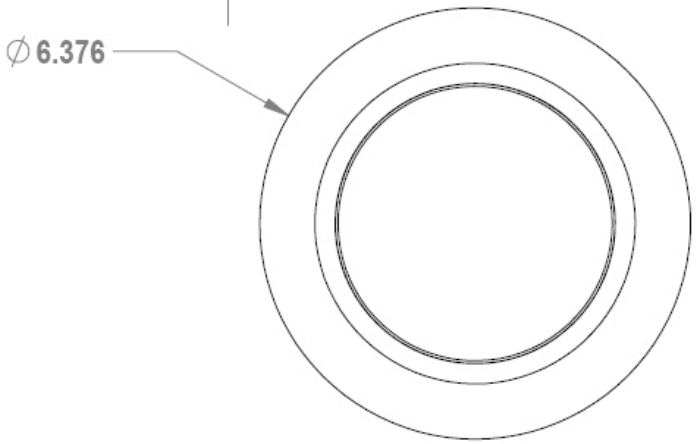
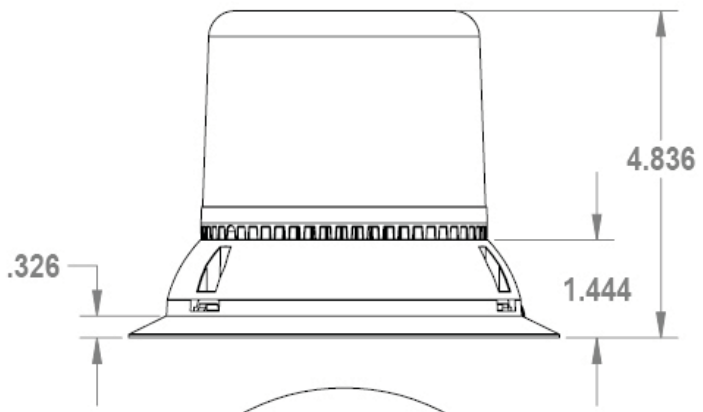
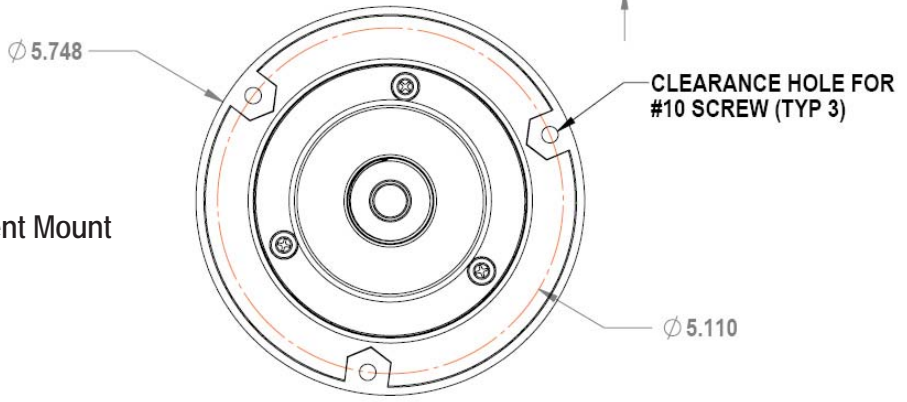

LS222 Magnetic Mount

# Current Draw

Amber/Red/Blue:	Flashing Current Draw: .85A Avg.	Flashing Current Draw: 1.0A Max.
-----------------	-------------------------------------	-------------------------------------

# Installation & Mounting

## Magnetic Mounting:

 **WARNING!** As with any magnetically-mounted warning device, its use on the exterior of a moving vehicle is at the sole discretion and responsibility of the user. This magnetic mount product provides a secure, temporary installation in most circumstances and is recommended for stationary use only.

The magnetic based beacon provides a secure, temporary installation. The beacon should be placed in the center of the roof where the least amount of curvature occurs. Check the magnet for debris before installation. Any foreign matter can reduce holding power and scratch the vehicle. The roof surface should be dry and have a dull, not glossy finish. A glossy, highly waxed surface will reduce the magnet's holding power. When placed, the beacon should adhere firmly. The user should not attempt to drive with the beacon in place should the unit slide or move easily.

## Permanent Mounting:

The permanent mount beacon provides a secure, permanent installation. Use the supplied foam gasket and screws to mount the beacon in the desired location. Wire routing should be taken into consideration when choosing a mounting location.

## Pipe Mounting (optional):

The beacon base will accept a standard 1" NPT pipe. Hand tighten the beacon base on the pipe thread until the pipe bottoms out inside the unit. **DO NOT OVERTIGHTEN - BASE IS PLASTIC.**

# Wiring Instructions

## Magnetic Mounting:

The magnetic mount beacon is equipped with a light plug with rocker switch, that plugs into a 12 Volt DC cigarette lighter outlet; rotate and push with reasonable moderate force to insure the best possible connection.

## Permanent Mount:

The beacon is terminated with a 6" long 4-wire cable harness that may be connected as follows:

<u>COLOR</u>	<u>FUNCTION</u>	<u>CONNECT TO</u>
Red	Power	+VDC
Black	Ground	Chassis Ground
Blue	Pattern Switching	Chassis Ground to Activate
Yellow	Synchronization	See Synchronization Section

## Operation:

### Synchronization (Permanent Mount Only):

To sync two beacons, configure both lights to display the same Phase 1 pattern. With the power off, connect the YELLOW wires from each lights together. When the lights are activated, their patterns will be synchronized. To configure the two lighthoods to alternate their patterns, advance the pattern of either beacon to the Phase 2 mode of the current pattern. A maximum of 8 lights may be sychronized.

### Setting the Flash Pattern (Magnetic base):

Depress the rocker switch on the lighter plug:

- Less than 1 second for the NEXT pattern
- 1 to 3 seconds for the PREVIOUS pattern
- 3 to 5 seconds for the DEFAULT pattern
- Greater than 5 seconds to TURN OFF the beacon

### Setting the Flash Pattern (Permanent base):

Connect blue wire to black wire (chassis ground):

- Less than 1 second for the NEXT pattern
- 1 to 3 seconds for the PREVIOUS pattern
- 3 to 5 seconds for the DEFAULT pattern
- Greater than 5 seconds to TURN OFF the beacon

## Maintenance:

The beacons are completely sealed units designed to be maintenance free. Refer to the guide below for help with troubleshooting. Should the unit be diagnosed as malfunctioning, remove unit and replace with a new module.

**WARNING!**



LED module housings may become hot with extended use. Allow modules to cool completely before attempting to remove.

TROUBLESHOOTING		
Problem	Probable Cause	Remedy
Lighthood does not activate	a. No power to unit	a. Check wire for loose connection
	b. Power input wire reversed	b. Reverse power wires
	c. Damaged or shortaged cabling	c. Check cables for damage
	d. Defective lighthood	d. Replace lighthood module
Lighthood is constantly ON	a. Control wire permanently grounded or shorted to GND	a. Avoid permanent grounding of control wire

## NOTES

# WARRANTY

Code 3, Inc.'s L.E.D. emergency devices are tested and found to be operational at the time of manufacture. Provided they are installed and operated in accordance with manufacturer's recommendations, Code 3, Inc. guarantees all parts and components except the lamps to a period of 1 year, LED Lighthouse modules to a period of 5 years (unless otherwise expressed) from the date of purchase or delivery, whichever is later. Units demonstrated to be defective within the warranty period will be repaired or replaced at the factory service center at no cost.

Use of lamp or other electrical load of a wattage higher than installed or recommended by the factory, or use of inappropriate or inadequate wiring or circuit protection causes this warranty to become void. Failure or destruction of the product resulting from abuse or unusual use and/or accidents is not covered by this warranty. Code 3, Inc. shall in no way be liable for other damages including consequential, indirect or special damages whether loss is due to negligence or breach of warranty.

**CODE 3, INC. MAKES NO OTHER EXPRESS OR IMPLIED WARRANTY INCLUDING, WITHOUT LIMITATION, WARRANTIES OF FITNESS OR MERCHANTABILITY, WITH RESPECT TO THIS PRODUCT.**

# PRODUCT RETURNS

If a product must be returned for repair or replacement\*, please contact our factory to obtain a Return Goods Authorization Number (RGA number) before you ship the product to Code 3, Inc. Write the RGA number clearly on the package near the mailing label. Be sure you use sufficient packing materials to avoid damage to the product being returned while in transit.

\*Code 3, Inc. reserves the right to repair or replace at its discretion. Code 3, Inc. assumes no responsibility or liability for expenses incurred for the removal and /or reinstallation of products requiring service and/or repair; nor for the packaging, handling, and shipping; nor for the handling of products return to sender after the service has been rendered.

PROBLEMS OR QUESTIONS? CALL OUR TECHNICAL ASSISTANCE HOTLINE (314) 996-2800  
[WWW.CODE3PSE.COM](http://WWW.CODE3PSE.COM)



Code 3, Inc.  
10986 N. Warson Road  
St. Louis, Missouri 63114-2029—USA  
Ph. (314) 426-2700 Fax (314) 426-1337  
[www.code3pse.com](http://www.code3pse.com)