

WHELEN[®]

ENGINEERING COMPANY INC.

Route 145, Winthrop Road,
Chester, Connecticut 06412

Phone: (860) 526-9504

Fax: (860) 526-4078

Internet: www.whelen.com

Sales e-mail: autosale@whelen.com

Canadian Sales e-mail: autocan@whelen.com

Customer Service e-mail: custserv@whelen.com

Installation Guide: LED Mirror-Beam™ 2006 Dodge Charger/Magnum

Safety First

This document provides all the necessary information to allow your Whelen product to be properly and safely installed. Before beginning the installation and/or operation of your new product, the installation technician and operator must read this manual completely. Important information is contained herein that could prevent serious injury or damage.

- **Proper installation of this product requires the installer to have a good understanding of automotive electronics, systems and procedures.**
- **If mounting this product requires drilling holes, the installer MUST be sure that no vehicle components or other vital parts could be damaged by the drilling process. Check both sides of the mounting surface before drilling begins. Also de-burr any holes and remove any metal shards or remnants. Install grommets into all wire passage holes.**
- **If this manual states that this product may be mounted with suction cups, magnets, tape or Velcro™, clean the mounting surface with a 50/50 mix of isopropyl alcohol and water and dry thoroughly.**
- **Do not install this product or route any wires in the deployment area of your air bag. Equipment mounted or located in the air bag deployment area will damage or reduce the effectiveness of the air bag, or become a projectile that could cause serious personal injury or death. Refer to your vehicle owners manual for the air bag deployment area. The User/Installer assumes full responsibility to determine proper mounting location, based on providing ultimate safety to all passengers inside the vehicle.**
- **For this product to operate at optimum efficiency, a good electrical connection to chassis ground must be made. The recommended procedure requires the product ground wire to be connected directly to the NEGATIVE (-) battery post.**
- **If this product uses a remote device to activate or control this product, make sure that this control is located in an area that allows both the vehicle and the control to be operated safely in any driving condition.**
- **Do not attempt to activate or control this device in a hazardous driving situation.**
- **This product contains either strobe light(s), halogen light(s), high-intensity LEDs or a combination of these lights. Do not stare directly into these lights. Momentary blindness and/or eye damage could result.**
- **Use only soap and water to clean the outer lens. Use of other chemicals could result in premature lens cracking (crazing) and discoloration. Lenses in this condition have significantly reduced effectiveness and should be replaced immediately. Inspect and operate this product regularly to confirm its proper operation and mounting condition. Do not use a pressure washer to clean this product.**
- **It is recommended that these instructions be stored in a safe place and referred to when performing maintenance and/or reinstallation of this product.**
- **FAILURE TO FOLLOW THESE SAFETY PRECAUTIONS AND INSTRUCTIONS COULD RESULT IN DAMAGE TO THE PRODUCT OR VEHICLE AND/OR SERIOUS INJURY TO YOU AND YOUR PASSENGERS!**

For warranty information regarding this product, visit www.whelen.com/warranty

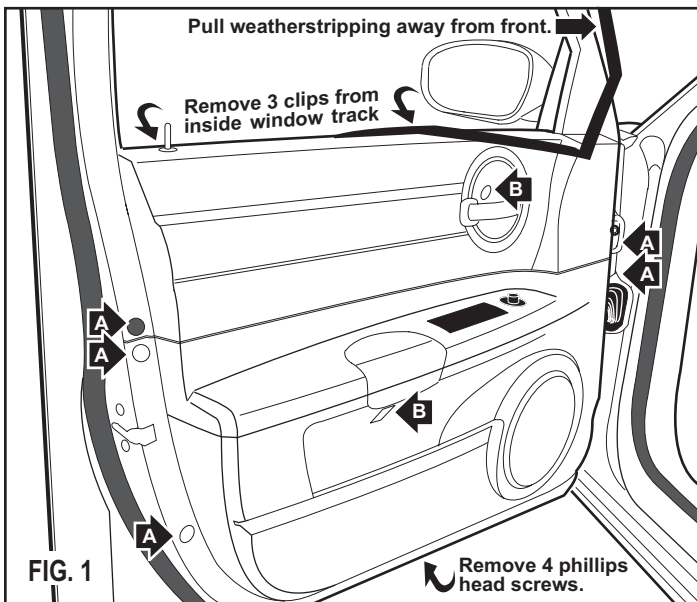

Removing the side mirror:

NOTE: This product can not be used if your vehicle is equipped with break-away mirrors.

1. Remove the driver side door panel from the vehicle (Fig. 1).

To remove the door panel: Remove the 5 caps labeled "A" (Fig. 1). Take a pen or other object and depress the center of the cap. This will disengage the cap so it can be removed, then **remove the phillips head screws** under the two covers labeled "B". **Remove the 3 clips** from inside the window track (Fig. 1). **Remove the 4 phillips head screws** from the bottom of the door panel. **Unhook the door opener rod and unplug the 3 electrical connectors** (Fig. 2) behind the door panel.

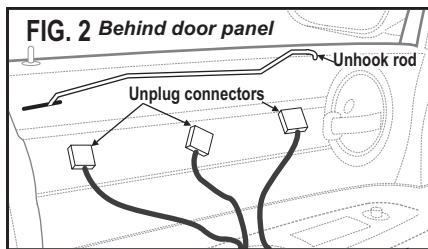

2. Pull weather-stripping off from around the front of the window that covers the door panel then pull the door panel off.

3. Remove the three hex nuts that secure the mirror to the vehicle (Fig. 4). Unplug the mirror's harness cable from the door's power harness and carefully remove the mirror assembly from the vehicle.

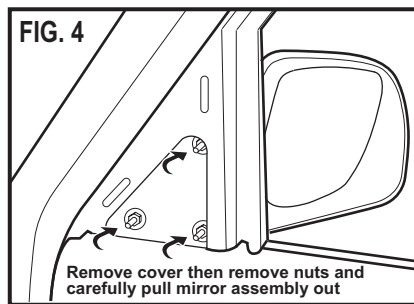

4. With the mirror off the vehicle, remove the gasket from its base then pull the loose piece of foam rubber out of the mirror assembly's wire hole (Fig. 5). Unplug the connector and pull the wire harness out of the mirror body.

Preparing the mirror housing:

1. Remove the 5 screws indicated in figure 5 then carefully pull the mirror assembly out of the mirror housing.

2. Drill a 3/8" hole in the back of the mirror body. Locate this hole approximately 1/2" below the seam that runs across the top of the front of the mirror housing and 1-1/2" from the inside edge.

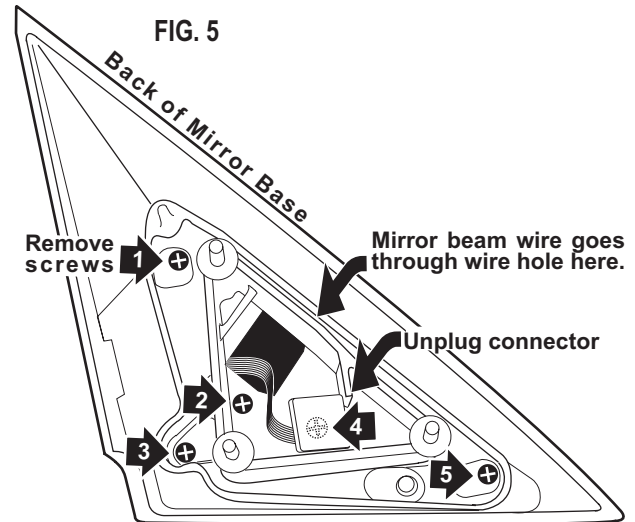
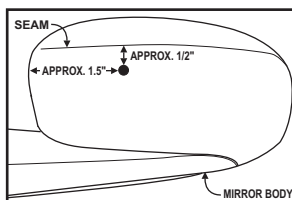

Affixing Mirror-Beam™ housing to mirror housing:

Note: The following procedure requires that the mirror assembly be no colder than 60°F (18°C).

1. Feed the Mirror-Beam™ harness through the mirror body and through the 3/8" hole drilled in step 2 of "Preparing the mirror housing". There should not be more than 4 or 5 inches of harness sticking out (Fig. 6).
2. Thoroughly clean the plastic mirror housing and the inside surface of the Mirror-Beam™ housing using a 50/50 mixture of isopropyl (not rubbing) alcohol and water. Dry completely.

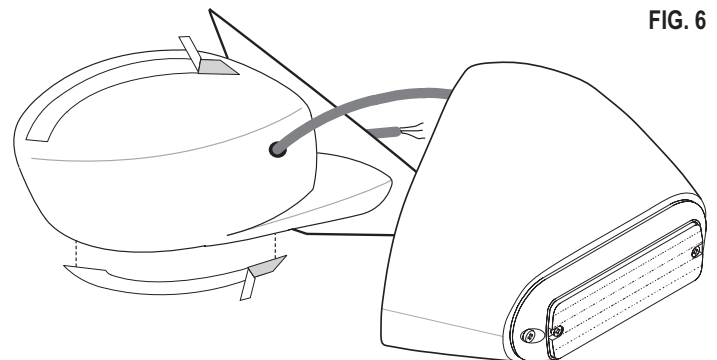

3. Locate the 6" strips of double sided adhesive tape included.
4. Place the Mirror-Beam™ housing onto the mirror housing. When properly positioned, the leading edge of the housing will be approximately 1/4" behind the leading edge of the mirror housing.
5. With the housing properly positioned, trace the outline of the housing onto the mirror housing using a suitable marker. Place one piece of tape on the top of the mirror housing and one on the bottom (Fig. 6). **Be sure to place these pieces behind the trace line.**
6. Fold the protective backing strips on each tape strip so that 1/2" to 3/4" of backing is extended over the edge of the mirror housing. Trim and remove the exposed tape.
7. Place the mirror housing mirror-side down on the workbench. Mount the Mirror-Beam™ housing onto the mirror housing. **The Mirror-Beam™ housing must fully engage the mirror housing.**
8. The protective backing strips must now be removed. To accomplish this, the Mirror-Beam™ housing must not be in contact with the backing strips. Using a small, flat blade screwdriver (or similar tool) gently pry the housing about 1/4" away from the mirror housing. Carefully pull the protective strip "tab" created in step 6, and gently remove it completely from the tape strip. Do not allow the Mirror-Beam™ housing to shift while removing the backing. Also, do not allow the strip to tear while being removed. Repeat process for remaining tape strip.

- Apply pressure to the Mirror-Beam™ housing at the tape locations. Maintain pressure for a minimum of 20 minutes to allow the tape to properly setup. This can be accomplished by wrapping the Mirror-Beam™/mirror housing tightly with adhesive tape. See important adhesion information at the end of this manual.
- Using a 1/8" drill bit and the screw hole in the Mirror-Beam™ housing as a template, drill a hole into the mirror housing. Use the #8 x 1/2" sheet metal screw (included) and secure the Mirror-Beam™ housing to the mirror housing (Fig. 7).

FIG. 7

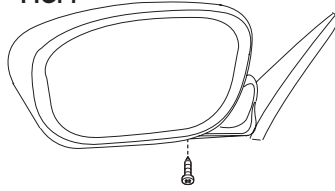

Re-assembling the Mirror-Beam™:

- Re-connect the mirror assembly to its main power harness. Route the MirrorBeam™ harness through the door, and through the rubber boot between the door along the same path as the vehicle's main power harness.
- Cut the non-insulated wire off the wiring harness (if present). Insert the PIN-type terminals into the provided connector. Select a connection style and confirm proper operation.

Depending on which lighthouse is installed in your Mirror-Beam™, you may be able to change flash patterns or synchronize lighthouses to flash simultaneously or alternately. This manual gives you basic wiring and installation. For information on the operation of your Mirror-Beam™ refer to the lighthouse manual included.

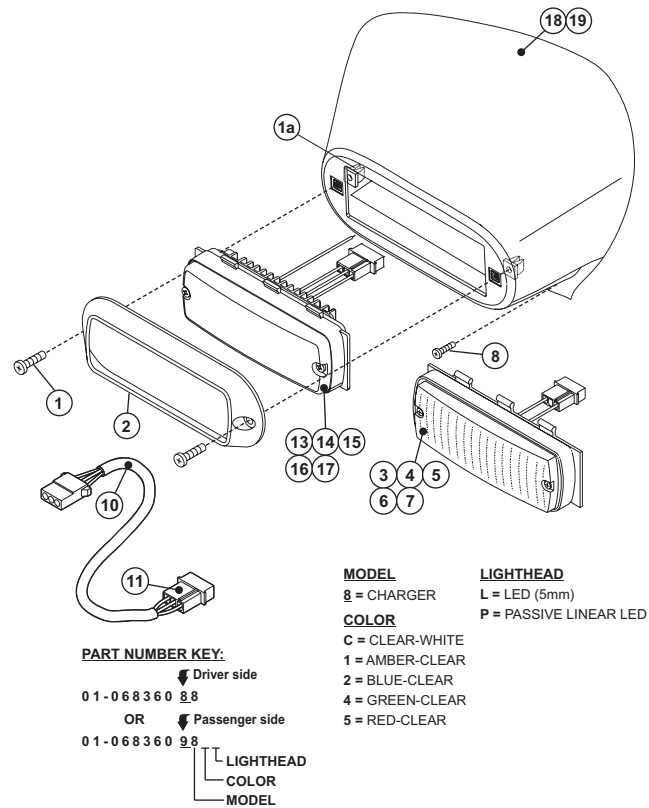

WARNING: All Customer supplied wires that connect to the positive terminal of the battery must be sized to supply at least 125% of the maximum operating current and FUSED at the battery to carry that load. DO NOT USE CIRCUIT BREAKERS WITH THIS PRODUCT!

IMPORTANT! The tape adhesive used in this procedure is fully bonded after 72 hours @ 70°F (21°C). During this period, do not expose the Mirror-Beam™ to any un-necessary force, such as the high-pressure water from a car wash.

WARNING: The outer surfaces of this product may be cleaned with mild soap and water. Use of any other chemicals may void the product warranty. Do not use a pressure washer.

IMPORTANT! Before returning the vehicle to active service, visually confirm the proper operation of this product, as well as all vehicle components/equipment.

IMPORTANT! Do not look directly at these LED's while they are on. Momentary blindness and/or eye damage could result!

QTY	QTY	ITEM	PART NUMBER	DESCRIPTION
	*		01-068360_8_L	MIRROR BEAM / LED / MAGNUM-CHARGER
*			01-068360_8_P	MIRROR BEAM / PASSIVE LINEAR / MAGNUM-CHARGER
2	2	1		SCREW / #8 X 5/8" PPHSMS SS
2	2	1a		#8 FASTEX GROMMET
1	1	2	11-763226-000	FLANGE / BLACK
-	A/R	3	02-0383558513	ASSY / LED FLASHER - AMBER / CLEAR 3 POS
-	A/R	4	02-0383558523	ASSY / LED FLASHER - BLUE / CLEAR 3 POS
-	A/R	5	02-03835585C3	ASSY / LED FLASHER - WHITE / CLEAR 3 POS
-	A/R	6	02-0383558543	ASSY / LED FLASHER - GREEN / CLEAR 3 POS
-	A/R	7	02-0383558553	ASSY / LED FLASHER - RED / CLEAR 3 POS
1	1	8	15-08141A-080	SCREW / #8 X 1/2" PPHSMS BLACK PHOS
2	2	9	66-0416642-00	TAPE / MOUNTING / not shown
1	1	10	46-0742172-15	CABLE ASSEMBLY, 3/C
1	1	11	01-0415532-00	KIT / CABLE INSTALLATION 3/C
1	1	12	26-0315001-14	TY-WRAP / 14 1/2" BLACK / not shown
A/R	-	13	01-0664633110	ASSY / PASSIVE LINEAR LED - AMBER/AMP
A/R	-	14	01-0664633120	ASSY / PASSIVE LINEAR LED - BLUE/AMP
A/R	-	15	01-0664633130	ASSY / PASSIVE LINEAR LED - WHITE/AMP
A/R	-	16	01-0664633140	ASSY / PASSIVE LINEAR LED - GREEN/AMP
A/R	-	17	01-0664633150	ASSY / PASSIVE LINEAR LED - RED/AMP
A/R	A/R	18	11-484250-000	HOUSING / PASS. SIDE - MAGNUM-CHARGER
A/R	A/R	19	11-484249-000	HOUSING / DRIVER SIDE - MAGNUM/CHARGER

Items 13, 14, 15, 16, & 17 (LINEAR)

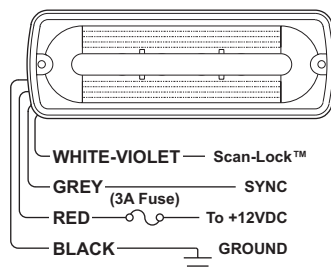

Items 3, 4, 5, 6 & 7 (LED)

