

WHELEN[®]

ENGINEERING COMPANY INC.

Route 145, Winthrop Road,
Chester, Connecticut 06412

Phone: (860) 526-9504

Fax: (860) 526-4078

Internet: www.whelen.com

Sales e-mail: autosale@whelen.com

Canadian Sales e-mail: autocan@whelen.com

Customer Service e-mail: custserv@whelen.com

Installation Guide: LED Motorcycle Power Box

Safety First

This document provides all the necessary information to allow your Whelen product to be properly and safely installed. Before beginning the installation and/or operation of your new product, the installation technician and operator must read this manual completely. Important information is contained herein that could prevent serious injury or damage.

- **Proper installation of this product requires the installer to have a good understanding of automotive electronics, systems and procedures.**
- **If mounting this product requires drilling holes, the installer MUST be sure that no vehicle components or other vital parts could be damaged by the drilling process. Check both sides of the mounting surface before drilling begins. Also de-burr the holes and remove any metal shards or remnants. Install grommets into all wire passage holes.**
- **If this product is mounted with tape or Velcro™, clean the mounting surface with a 50/50 mix of isopropyl alcohol and water and dry thoroughly.**
- **Do not install this product or route any wires in the deployment area of your air bag. Equipment mounted or located in the air bag deployment area will damage or reduce the effectiveness of the air bag, or become a projectile that could cause serious personal injury or death. Refer to your vehicle owners manual for the air bag deployment area. The User/Installer assumes full responsibility to determine proper mounting location, based on providing ultimate safety to all passengers inside the vehicle.**
- **For this product to operate at optimum efficiency, a good electrical connection to chassis ground must be made. The recommended procedure requires the product ground wire to be connected directly to the NEGATIVE (-) battery post.**
- **If this product uses a remote device to activate or control this product, make sure that this control is located in an area that allows both the vehicle and the control to be operated safely in any driving condition.**
- **Do not attempt to activate or control this device in a hazardous driving situation.**
- **If this product contains strobe light(s), halogen light(s) or high-intensity LEDs, do not stare directly into these lights at a close distance. Momentary blindness and/or eye damage could result.**
- **If this product contains strobe light(s), halogen light(s) or high-intensity LEDs, use only soap and water to clean the lamp lens. Use of other chemicals could result in premature lens cracking (crazing) and discoloration. Lenses in this condition have significantly reduced effectiveness and should be replaced immediately. Inspect and operate this product regularly to confirm its proper operation and mounting condition. Do not use a pressure washer to clean this product.**
- **It is recommended that these instructions be stored in a safe place and referred to when performing maintenance and/or reinstallation of this product.**
- **FAILURE TO FOLLOW THESE SAFETY PRECAUTIONS AND INSTRUCTIONS COULD RESULT IN DAMAGE TO THE PRODUCT OR VEHICLE AND/OR SERIOUS INJURY TO YOU AND YOUR PASSENGERS!**

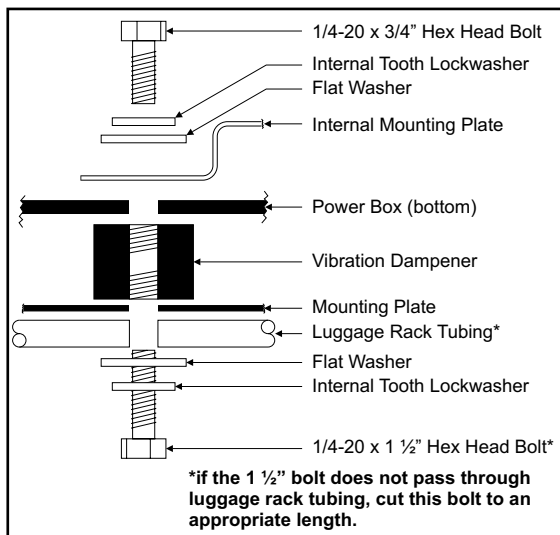
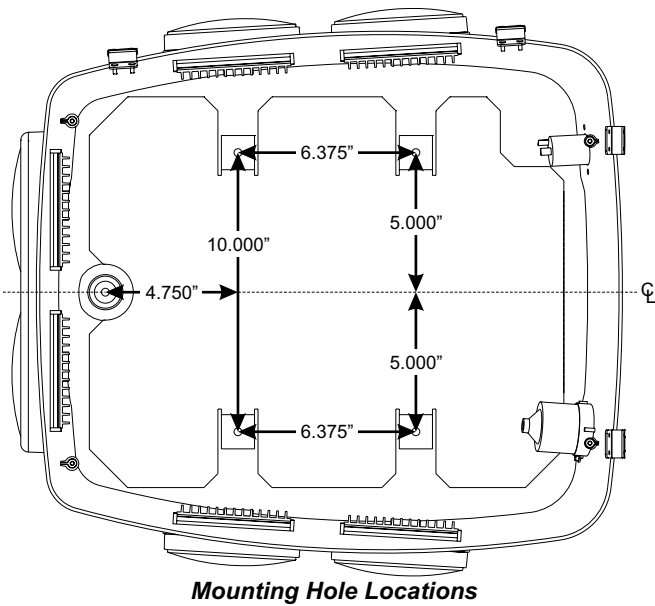
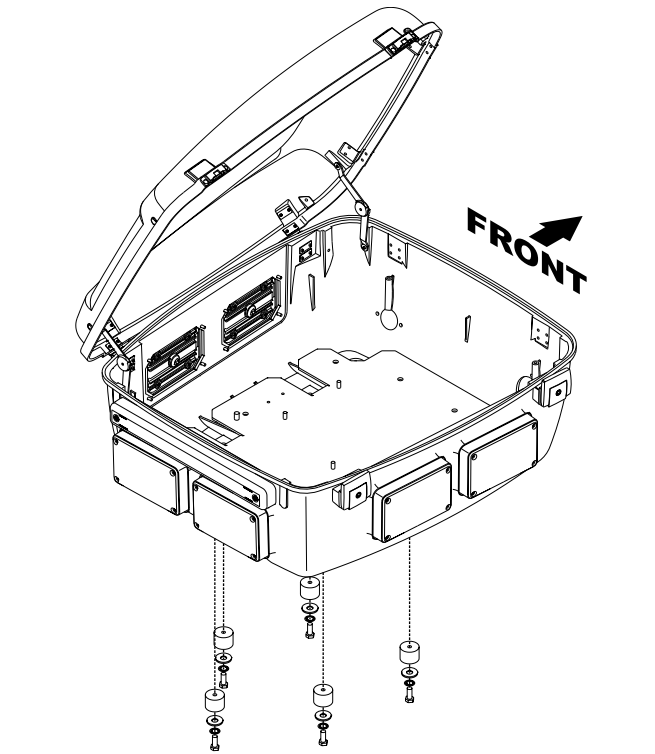

Mounting:

This box requires the presence of a mounting plate secured to the motorcycle's luggage rack. If the bike in question is not equipped with a mounting plate, one must be fabricated prior to installation of this box. Five mounting holes (.281" dia.) are required to mount this box.

If the motorcycle is already equipped with a mounting plate, it may be necessary to drill the 5 mounting holes required for this installation.

Use the diagram shown to determine the precise location of these holes.

1. Position the box onto the mounting plate. Align the 5 vibration dampeners with the 5 mounting holes in the mounting plate.
2. Using the illustrations shown, secure the box to the mounting plate using the provided hardware.

Note: Your luggage rack may already have the correct mounting holes drilled. Check the measurements below and if these holes already exist at the proper distance, remove any existing mounting hardware from the holes and secure the box with the supplied mounting hardware.

3. Place the box into its mounting position on the deck and secure it with the supplied mounting hardware as shown in the diagram.

Wiring:

Diagrams for optional equipment are found below. Refer to the diagram on the following page for general motorcycle box wiring information.

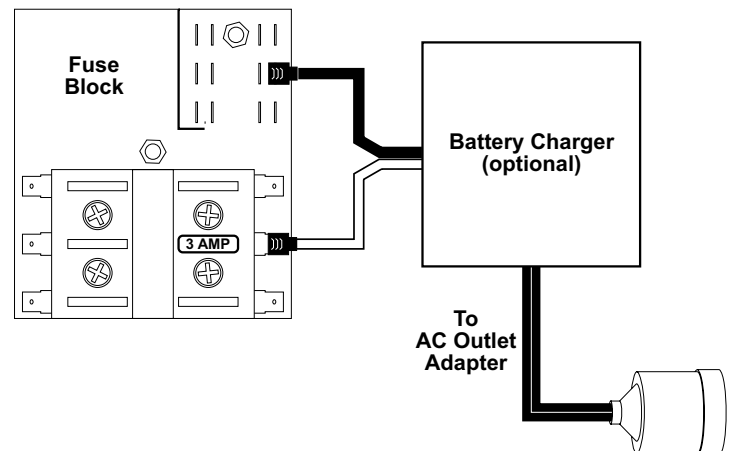
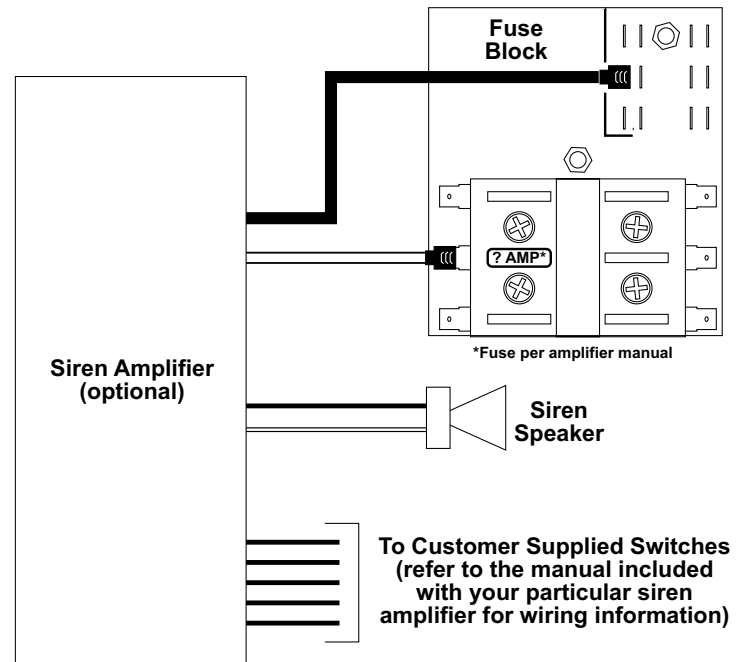

ScanLock™ FLASH PATTERNS

- 1 SignalAlert™ (Phase 1)
- 2 SignalAlert™ (Phase 2)
- 3 SignalAlert™ (Simultaneous)
- 4 ComeFlash™ (Phase 1)
- 5 ComeFlash™ (Phase 2)
- 6 ComeFlash™ (Simultaneous)
- 7 SingleFlash 75 (Phase 1)
- 8 SingleFlash 75 (Phase 2)
- 9 SingleFlash 75 (Simultaneous)
- 10 SingleFlash 150 (Phase 1)
- 11 SingleFlash 150 (Phase 2)
- 12 SingleFlash 150 (Simultaneous)
- 13 SingleFlash 375 (Phase 1)
- 14 SingleFlash 375 (Phase 2)
- 15 SingleFlash 375 (Simultaneous)
- 16 DoubleFlash 75 (Phase 1)
- 17 DoubleFlash 75 (Phase 2)
- 18 DoubleFlash 75 (Simultaneous)
- 19 ModuFlash™ (Phase 1)
- 20 ModuFlash™ (Phase 2)
- 21 ModuFlash™ (Simultaneous)
- 22 ActionFlash™ (Phase 1)
- 23 ActionFlash™ (Phase 2)
- 24 ActionFlash™ (Simultaneous)
- 25 ActionScan™ (Phase 1)
- 26 ActionScan™ (Phase 2)
- 27 ActionScan™ (Simultaneous)
- 28 Invalid Pattern For This Application. Do Not Use.

Flash Pattern Phase Modes

The flasher used in this application has three different phase modes. Each pattern is available in each of these modes. Each mode effects the relationship between each outlet:

Phase 1 - Outlets 1, 3, 5 & 7 will alternate with Outlets 2, 4, 6 & 8

Phase 2 - Outlets 1, 2, 3 & 4 will alternate with Outlets 5, 6, 7 & 8

Phase 3 - All Outlets flash simultaneously

Pattern Activation Procedure

TO CYCLE THROUGH ALL PATTERNS: Apply +12 volts to the WHT/VIO wire for less than 1 second and release to cycle forward. Apply +12 volts to the WHT/VIO wire for more than 1 second and release to cycle backward.

TO SET A PATTERN AS DEFAULT: When the desired pattern is displayed, allow it to run for more than 5 seconds. The lightning will now display this pattern when active.

TO RESET TO THE FACTORY DEFAULT PATTERN: Turn off power, apply +12 volts to the WHT/VIO wire, then turn power on.

Note: If the installer wishes to connect the pattern selection wire (WHT/VIO) to a switch, a momentary switch (normally open) is recommended for this use.

Outlet Activation

Apply +12VDC to the appropriate control wire(s) to activate the desired outlets. These outlets will remain active until +12VDC is removed from the control wire(s). Note: This flasher uses low current switching (100mA per control wire)

Low Power Operation

Apply +12VDC to the VIO wire for Low Power Operation. Low Power Operation will remain in effect until +12VDC is removed from the VIO wire. A SP/ST switch is recommended for this use.

Control Connector (Rear View)

- 1 = ScanLock (WHT/VIO)
- 2 = Low Power (VIO)
- 3 = Outlets 1&2 (BRN)
- 4 = Outlets 3&4 (RED)
- 5 = Outlets 5&6 (ORG)
- 6 = Outlets 7&8 (YEL)

Power Connector (Rear View)

- 1 = Ground (BLK)
- 2 = +12VDC (RED)*

*Fuse @ 10 Amp

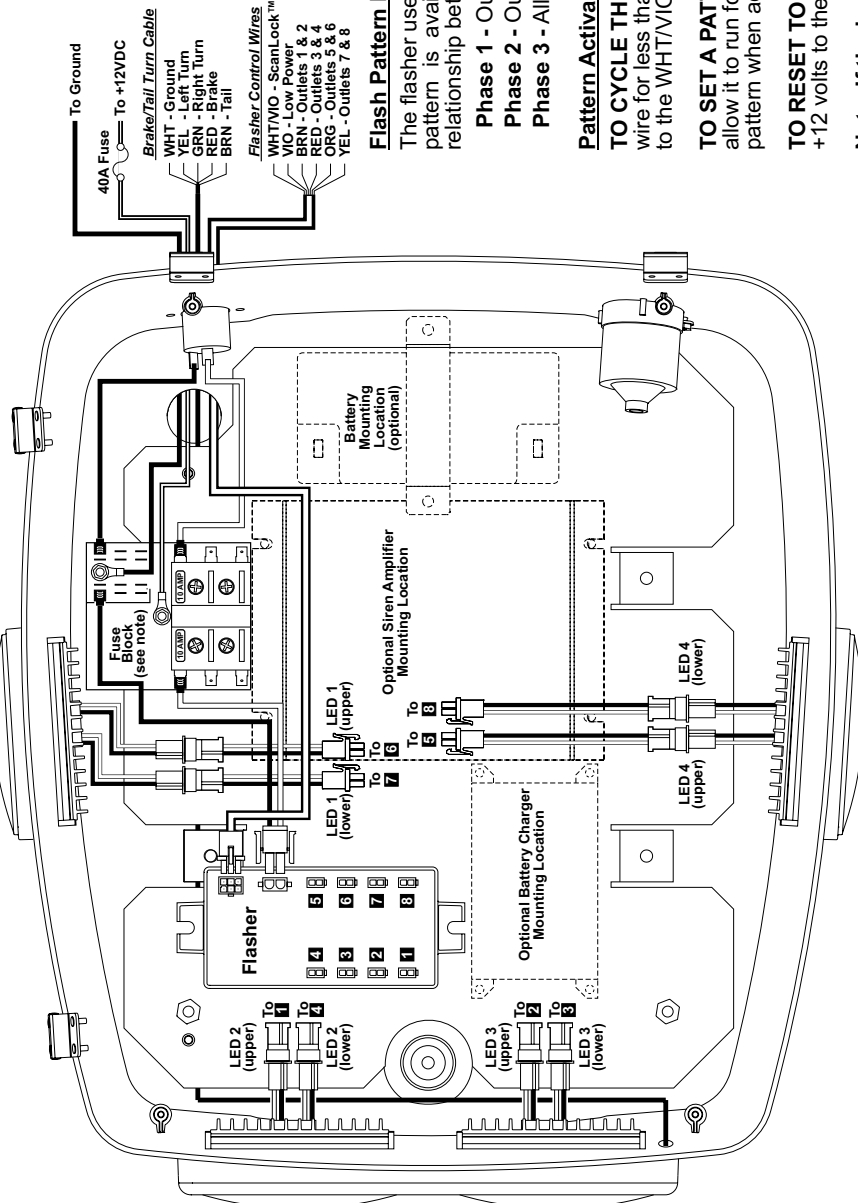

FUSE BLOCK NOTE!
Max. current draw per circuit = 15A
(Fuse circuit @ 125% of max. current draw)

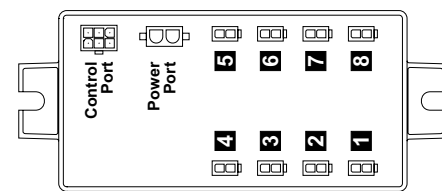
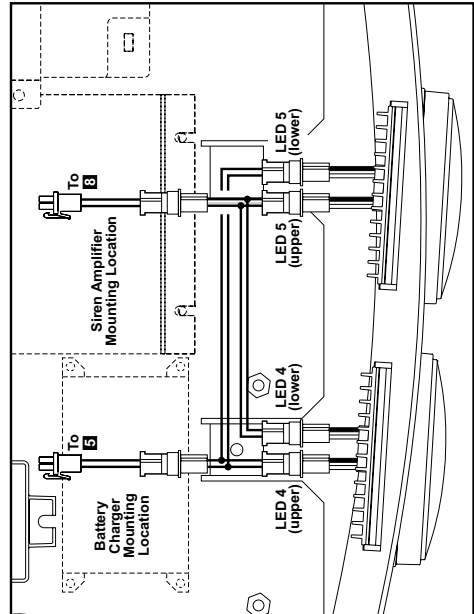

All customer supplied wires that connect to the Positive (+) terminal of the battery, must be sized to supply at least 125% of the maximum operating current and be fused at the battery to carry that load.