

WHELEN[®] ENGINEERING COMPANY INC.

51 Winthrop Road
 Chester, Connecticut 06412-0684
 Phone: (860) 526-9504
 Fax: (860) 526-4078
 Internet: www.whelen.com
 Sales e-mail: autosale@whelen.com
 Canadian Sales e-mail: autocan@whelen.com
 Customer Service e-mail: custserv@whelen.com

Installation Guide: Model ALPHA22R Remote Siren Amplifier

DANGER! Sirens produces extremely loud emergency warning tones! Exposure to these tones without proper and adequate hearing protection, could cause ear damage and/or hearing loss! The Occupational Safety & Health Administration (www.osha.gov) provides information necessary to determine safe exposure times in Occupational Noise Exposure Section 1910.95. Until you have determined the safe exposure times for your specific application, operators and anyone else in the immediate vicinity should be required to wear an approved hearing protection device. **FAILURE TO FOLLOW THIS RECOMMENDATION COULD CAUSE HEARING LOSS!**

Safety First

This document provides all the necessary information to allow your Whelen product to be properly and safely installed. Before beginning the installation and/or operation of your new product, the installation technician and operator must read this manual completely. Important information is contained herein that could prevent serious injury or damage.

- Proper installation of this product requires the installer to have a good understanding of automotive electronics, systems and procedures.
- If mounting this product requires drilling holes, the installer **MUST** be sure that no vehicle components or other vital parts could be damaged by the drilling process. Check both sides of the mounting surface before drilling begins. Also de-burr any holes and remove any metal shards or remnants. Install grommets into all wire passage holes.
- If this manual states that this product may be mounted with suction cups, magnets, tape or Velcro™, clean the mounting surface with a 50/50 mix of isopropyl alcohol and water and dry thoroughly.
- Do not install this product or route any wires in the deployment area of your air bag. Equipment mounted or located in the air bag deployment area will damage or reduce the effectiveness of the air bag, or become a projectile that could cause serious personal injury or death. Refer to your vehicle owners manual for the air bag deployment area. The User/Installer assumes full responsibility to determine proper mounting location, based on providing ultimate safety to all passengers inside the vehicle.
- For this product to operate at optimum efficiency, a good electrical connection to chassis ground must be made. The recommended procedure requires the product ground wire to be connected directly to the **NEGATIVE (-)** battery post.
- If this product uses a remote device to activate or control this product, make sure this control is located in an area that allows both the vehicle and the control to be operated safely in any driving condition. **DO NOT ATTEMPT TO ACTIVATE OR CONTROL THIS DEVICE IN A HAZARDOUS DRIVING SITUATION.**
- It is recommended that these instructions be stored in a safe place and referred to when performing maintenance and/or reinstallation of this product.
- **FAILURE TO FOLLOW THESE SAFETY PRECAUTIONS AND INSTRUCTIONS COULD RESULT IN DAMAGE TO THE PRODUCT OR VEHICLE AND/OR SERIOUS INJURY TO YOU AND YOUR PASSENGERS!**

ACTIVATION OF THIS SIREN MAY DAMAGE UNPROTECTED EARS!



CAUTION

Loud siren noise can cause hearing damage and/or loss. Refer to OSHA Section 1910.95 prior to putting ANY siren into service!

For warranty information regarding this product, visit www.whelen.com/warranty

WARNING! If the ALPHA22R is replacing the siren amplifier in an existing siren system, that systems switches MUST be rewired to match the corresponding Alpha switch wiring diagram found in this manual. If the existing system does not use Alpha switches, refer to the wiring information on page 5 to rewire your switches.

Mounting the ALPHA22R

1. Locate a suitable mounting location for the ALPHA22R. The vertical wall between the trunk and the passenger compartment is often a good choice and is the method discussed in this manual.
2. Be sure that the remote amplifier fits properly and does not interfere with any parts of the trunk lid or seat back.
3. Position the remote amplifier on the proposed mounting location. Using an awl or other suitable tool, scribe the mounting surface where the mounting holes are to be drilled.

CAUTION! As mounting the ALPHA22R will require drilling, it is absolutely necessary to make sure that no other vehicle components could be damaged by the drilling process. If any vehicle component could suffer any potential harm, select a different mounting location.

4. Carefully drill the mounting holes using a drill bit sized for a #10 sheet metal screw.
5. Using the supplied #10 x 3/4" sheet metal screws, secure the remote amplifier to the vertical trunk wall.

Wiring the ALPHA22R 16 position connector

Connecting to Power:

1. Extend the RED and BLACK wires through the firewall and into the engine compartment.
2. Follow the factory wiring harness towards your vehicle's battery.

WARNING! All customer supplied wires that connect to the positive terminal of the battery, must be sized to supply at least 125% of the maximum operating current and fused "AT THE BATTERY" to carry that load.

3. Connect the RED wire to one end of a user supplied fuse block. Do not connect this unit to the battery yet!
4. Connect the BLACK wire directly to the NEGATIVE battery terminal.

Dip Switch Functions:

Dip Switch 1	Dip Switch 2	Description of tonal qualities
OFF	OFF	HF 3rd tone & T3 is Piercer (Default)
OFF	ON	HF 3rd tone & T3 is Hi/Lo
ON	OFF	Motorcycle mode
ON	ON	California Title-13 compliant operation.

Dip Switch 3	Yelp Override Options
OFF	Wail has normal Yelp override (Default)
ON	Wail has 10-second Yelp override

Connecting to your Speaker(s):

1. Route the ORANGE, YELLOW and BROWN wires along the factory wiring harness towards your speaker(s).
2. Connect the ORANGE wire to the POSITIVE (+) terminal on speaker #1. If two speakers (100 watt max. each) are used, connect the YELLOW wire to the POSITIVE (+) terminal on speaker #2.
3. Connect the BROWN wire to the NEGATIVE (-) terminal on speaker #1. If two speakers are used, splice and connect the BROWN wire to the NEGATIVE (-) terminals on speakers #1 and #2.

Siren Operation

Hands Free Operation - With the dip switches in their default positions, applying +12VDC to the WHT/ORN wire initiates Hands-Free siren control. Siren functions are now placed in a stand-by mode. Siren tones are activated by a single tap on the vehicle's steering wheel horn ring (if the vehicle's horn has been wired to the HORN RING input). The first tap produces a WAIL tone (a steady rise and fall tone). A second tap produces a YELP tone (a fast rise and fall tone.) A third tap produces a Piercer tone (an extremely fast rise and fall tone). The next tap returns the siren to a wail tone and the cycle repeats itself. Two quick, successive taps will stop the siren.

Manual Operation - When Dip Switch 6 is moved to the ON position (Dip Switch 5 must be OFF), Hands-free operation is replaced with Manual siren operation. In this position, the siren is in a stand-by state where no tones have been activated, but is waiting for another action to be taken by the operator. This position is often the best choice when manual operation of the siren is desired.

The behavior of Manual siren operation is determined by dip switch 4. In the default position (OFF), activating the HORN RING input will result in a WAIL tone ramping up to the peek frequency and stopping when the HORN RING input is released.

If Dip Switch 4 is moved to the ON position, activating the HORN RING input will result in a WAIL tone ramping up to the peak frequency and ramping down to a stop at the lowest frequency when the HORN RING input is released.

Connecting to switches:

The operation of the ALPHA22R is determined by the dip switch settings. The following tables will outline the various dip switch configurations. Refer to the wiring diagrams on the following pages for information on how the ALPHA22R is wired using ALPHA-series switches. Generic wiring information is also provided for installations that will not use ALPHA switches.

Dip Switch 4	Manual Siren Control Settings
OFF	Manual button Stop (Default)
ON	Manual Coast

Dip Switch 5	Dip Switch 6	Priority Functions
OFF	OFF	Yelp supercedes Wail (Default)
ON	OFF	Wail supercedes Yelp
OFF	ON	Yelp supercedes Wail / Manual replaces Hands-Free
ON	ON	Invalid Selection - Do Not Use

Wiring Diagram using the Alpha 1 switch assembly

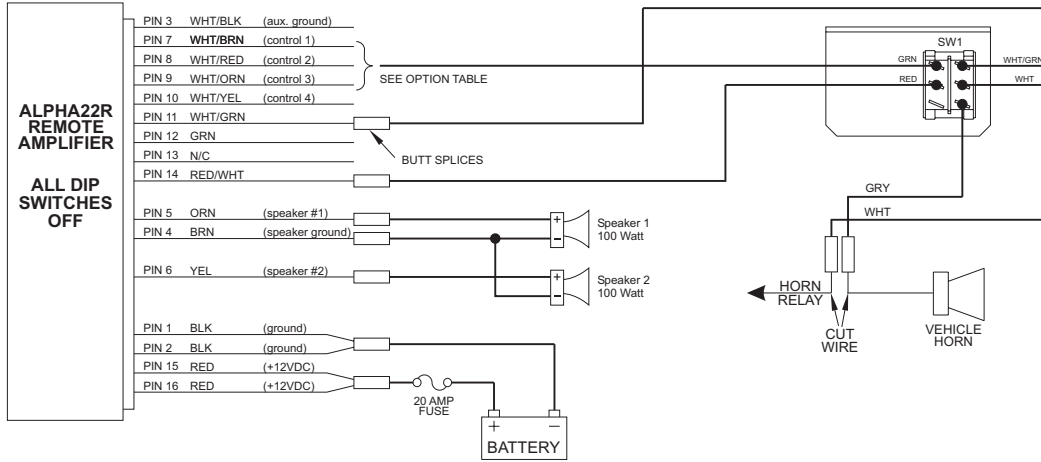

When switch is in this position....	connecting the GREEN to this wire will generate this siren tone....	and the Horn Ring activated override tone is....
SW1 ON	WHT/BRN = Wail WHT/RED = Yelp WHT/ORN = Hands-Free Mode	Yelp Piercer Hands-Free Cycle
SW1 OFF	NO TONE	Vehicle Horn

Wiring Diagram using the Alpha 2 switch assembly

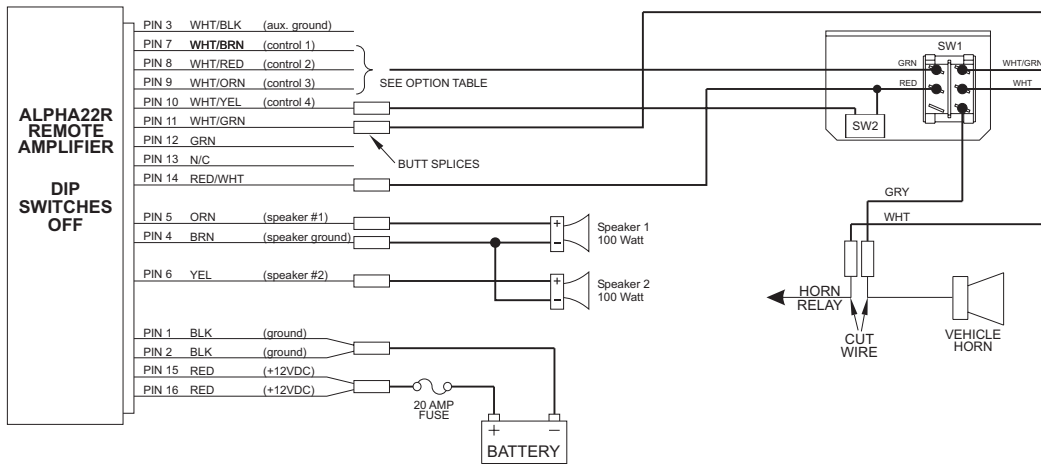

When switch is in this position....	connecting the GREEN to this wire will generate this siren tone....	and pressing SW2 will activate....	and the Horn Ring activated override tone is....
SW1 ON	WHT/BRN = Wail WHT/RED = Yelp WHT/ORN = Hands-Free Mode	Air Horn	Yelp Piercer Hands-Free Cycle
SW1 OFF	NO TONE	Air Horn	Vehicle Horn

Wiring Diagram using the Alpha 3 switch assembly

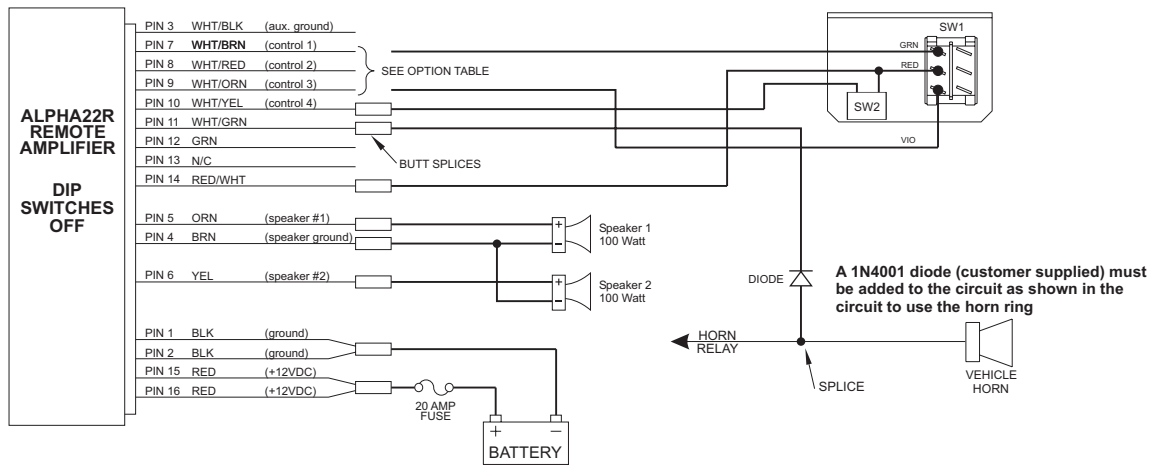

When switch is in this position....	connecting the GREEN wire to this wire will determine Tone 1....	and pressing SW2 will activate....	and the Horn Ring activated override tone is....
SW1 Tone 1	WHT/BRN = Wail WHT/RED = Yelp WHT/ORN = Hands-Free Mode	Air Horn Air Horn Air Horn	Yelp + Vehicle Horn Piercer + Vehicle Horn Hands-Free Cycle + Vehicle Horn
SW1 OFF	NO TONE	Air Horn	Vehicle Horn
When switch is in this position....	connecting the VIOLET wire to this wire will determine Tone 2....	and pressing SW2 will activate....	and the Horn Ring activated override tone is....
SW1 Tone 2	WHT/BRN = Wail WHT/RED = Yelp WHT/ORN = Hands-Free Mode	Air Horn Air Horn Air Horn	Yelp + Vehicle Horn Piercer + Vehicle Horn Hands-Free Cycle + Vehicle Horn

Wiring Diagram using the Alpha 4 switch assembly

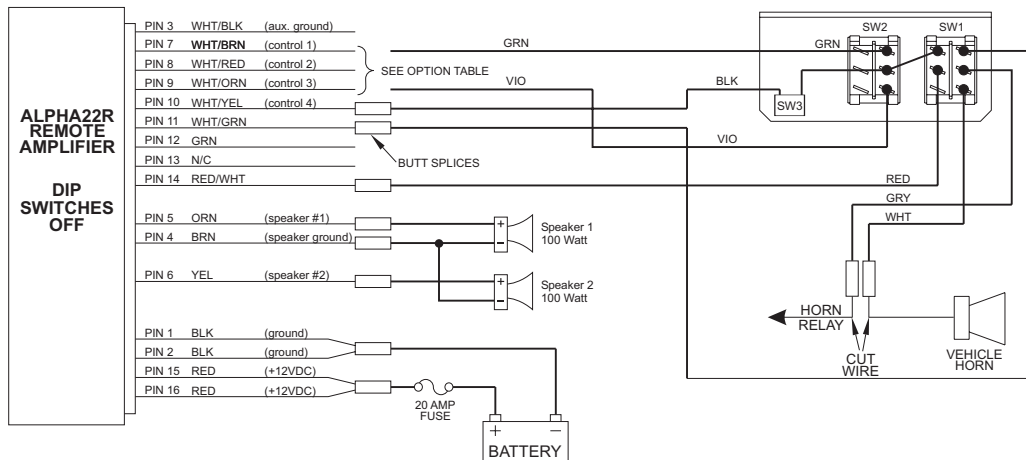

When switches are in this position....	connecting the GREEN wire to this wire will determine Tone 1....	and pressing SW3 will activate....	and the Horn Ring activates....
SW2 TONE 1	SW1 ON	WHT/BRN = Wail WHT/RED = Yelp WHT/ORN = Hands-Free Mode	Air Horn Air Horn Air Horn
	SW1 OFF	NO TONE	NO TONE
SW2 OFF	SW1 ON	NO TONE	Air Horn
	SW1 OFF	NO TONE	Vehicle Horn
When switches are in this position....	connecting the VIOLET wire to this wire will determine Tone 2....	and pressing SW3 will activate....	and the Horn Ring activates....
SW2 TONE 2	SW1 ON	WHT/BRN = Wail WHT/RED = Yelp WHT/ORN = Hands-Free Mode	Air Horn Air Horn Air Horn
	SW1 OFF	NO TONE	NO TONE

The following diagrams provides basic switching information for installations that will not use Alpha switches.

Specifications

Input Voltage	- 13.5 VDC ±20%
Input Current (Off)	- 0 mA
Input Current (Stand-By)	- 90mA
Input Current (Siren)	- 16 AMPS (TYP.)
Output Voltage	- 34 V RMS (MAX.)
Speaker	- 11 ohm (Two, 100 Watt MAX.)
Output Power@15VDC	- 200 WATTS (MAX.)
Control Voltage	- Input Voltage
Control Current	- 125mA (TYP.)
H/R Voltage	- Input Voltage or Ground
H/R Current	- 15mA (TYP.)
Operating Temp.	- -30° C. to +60° C.
Operating Humidity	- 95% Non Condensing

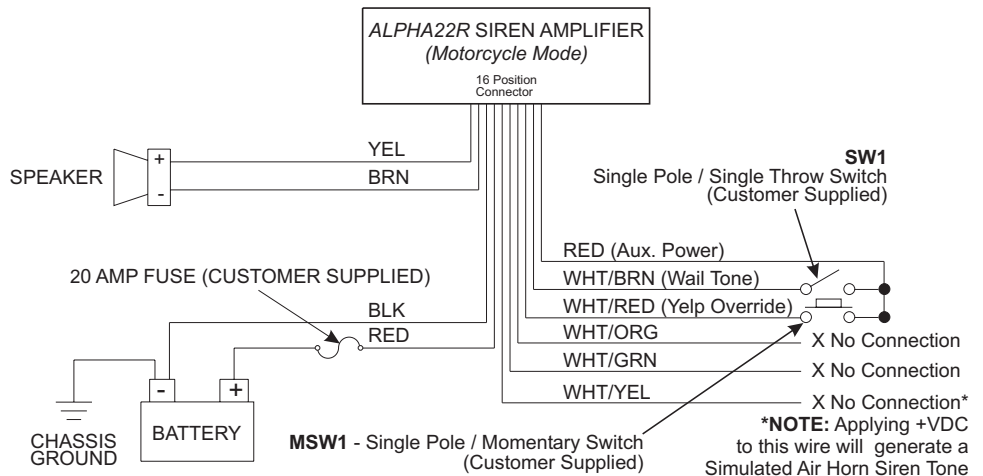
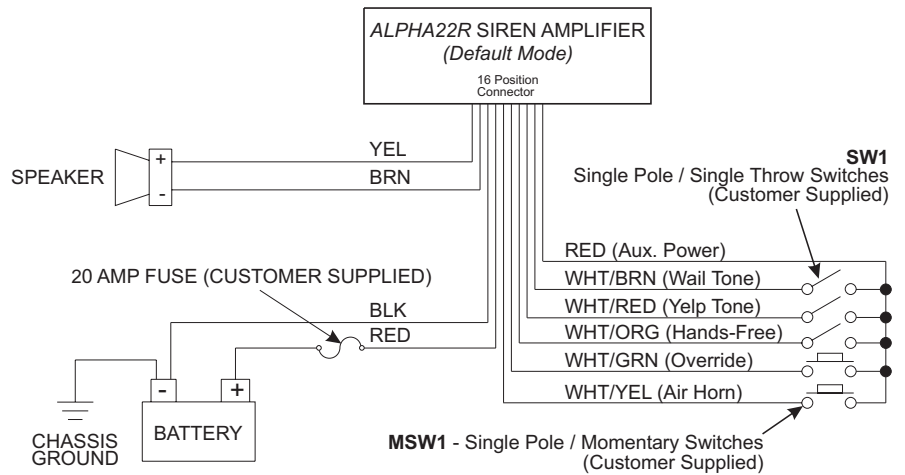

Connecting to your Horn Relay:

1. Locate your vehicle's horn relay. Now locate the wire that connects the vehicle horn to the horn relay and cut this wire.
2. Extend each end of the cut wire (using a minimum 16 gauge wire) to a user supplied SPDT horn transfer switch.
3. Connect the wire coming from the horn relay to the switch "wiper" as shown in the wiring diagrams.
4. Connect the wire coming from the horn to one side of the switch as shown in the wiring diagrams.
5. Connect the WHITE/GREEN* wire from the 16 position connector to the other side of the switch as shown in the wiring diagrams.

*** The wiring diagrams assume the vehicle uses a positive activated horn ring signal. If this signal is ground activated, use the solid GREEN wire instead of the WHITE/GREEN wire**

The installation of your ALPHA22R series siren amplifier will be complete after the fuse block wire is connected to the POSITIVE (+) terminal of the battery. After this connection has been made, visually inspect the fuses at the back of the amplifier and at the battery. If either of these fuses is blown, carefully inspect all of the circuit wires and make sure they are wired correctly. Replace the blown fuses with ones of an identical amp rating as the original. If these fuses blow after installation or activation, contact Whelen Engineering Technical Support.

Wire Gauge Calculation Chart

		Wire Gage (AWG)										
		22	20	18	16	14	12	10	8	6	4	2
Current Draw (AMPS)	5	6	9.5	15	24.5	39	62	98	156	248	395	629
	10	3	5	7.5	12	19.5	31	49	78	124	197	314
	15	INS.	3	5	8	13	20.5	32.5	52	82.5	131	209
	20	INS.	INS.	4	6	9.5	15.5	24.5	39	62	98.5	157
	25	INS.	INS.	3	5	8	12.5	19.5	31	49.5	79	125
	30	INS.	INS.	INS.	4	6.5	10.5	16.5	26	41.5	66	104
	35	INS.	INS.	INS.	3.5	5.5	9	14	22.5	35.5	56.5	89.5
	40	INS.	INS.	INS.	3	5	7.5	12.5	19.5	31	49.5	78.5
	45	INS.	INS.	INS.	INS.	4.5	7	11	17.5	27.5	44	69.5
	50	INS.	INS.	INS.	INS.	4	6	10	15.5	25	39.5	63
	55	INS.	INS.	INS.	INS.	3.5	5.5	9	14	22.5	36	57
	60	INS.	INS.	INS.	INS.	3	5	8	13	20.5	33	52.5
	65	INS.	INS.	INS.	INS.	3	5	7.5	12	19	30.5	48.5
	70	INS.	INS.	INS.	INS.	3	4.5	7	11	17.5	28	45
	75	INS.	INS.	INS.	INS.	INS.	4	6.5	10.5	16.5	26.5	42
	80	INS.	INS.	INS.	INS.	INS.	4	6	10	15.5	24.5	39
	85	INS.	INS.	INS.	INS.	INS.	3.5	6	9	14.5	23	37
90	INS.	INS.	INS.	INS.	INS.	3.5	5.5	8.5	14	22	35	
95	INS.	INS.	INS.	INS.	INS.	3.5	5	8	13	21	33	
100	INS.	INS.	INS.	INS.	INS.	3	5	8	12.5	19.5	31.5	

INS. = Insufficient All Distances Shown Are In Feet

To use this chart...

1. Determine the amount of current being drawn through the wire. Locate this number in the vertical left-hand column. If the current value is between adjacent values, use the higher number.
2. Follow this row until the length of the installed wire is shown. If the exact length is between adjacent values, use the higher number. Follow this column upwards to find the recommended size (gage) for this wire.

In the example shown below, the size for a wire with an installed length of 36 feet, through which 22 amps of current will be drawn, must be determined.

A row for 22 amps is not shown, so the row for 25 amps will be used. Follow this row to the right. A column for 36 feet is not shown, so the column for 49.5 feet will be used. Following this column to the top will show that the size of this wire must be at least 6 gage.