

# WHELEN<sup>®</sup>

ENGINEERING COMPANY INC.

51 Winthrop Road  
Chester, Connecticut 06412-0684  
Phone: (860) 526-9504  
Fax: (860) 526-4078  
Internet: [www.whelen.com](http://www.whelen.com)  
Sales e-mail: [autosale@whelen.com](mailto:autosale@whelen.com)  
Canadian Sales e-mail: [autocan@whelen.com](mailto:autocan@whelen.com)  
Customer Service e-mail: [custserv@whelen.com](mailto:custserv@whelen.com)

## Installation Guide: Edge<sup>®</sup> 9M Lightbar

### Safety First

This document provides all the necessary information to allow your Whelen product to be properly and safely installed. Before beginning the installation and/or operation of your new product, the installation technician and operator must read this manual completely. Important information is contained herein that could prevent serious injury or damage.

- Proper installation of this product requires the installer to have a good understanding of automotive electronics, systems and procedures.
- If mounting this product requires drilling holes, the installer **MUST** be sure that no vehicle components or other vital parts could be damaged by the drilling process. Check both sides of the mounting surface before drilling begins. Also de-burr any holes and remove any metal shards or remnants. Install grommets into all wire passage holes.
- If this manual states that this product may be mounted with suction cups, magnets, tape or Velcro<sup>®</sup>, clean the mounting surface with a 50/50 mix of isopropyl alcohol and water and dry thoroughly.
- Do not install this product or route any wires in the deployment area of your air bag. Equipment mounted or located in the air bag deployment area will damage or reduce the effectiveness of the air bag, or become a projectile that could cause serious personal injury or death. Refer to your vehicle owner's manual for the air bag deployment area. The User/Installer assumes full responsibility to determine proper mounting location, based on providing ultimate safety to all passengers inside the vehicle.
- For this product to operate at optimum efficiency, a good electrical connection to chassis ground must be made. The recommended procedure requires the product ground wire to be connected directly to the **NEGATIVE (-)** battery post.
- If this product uses a remote device to activate or control this product, make sure that this control is located in an area that allows both the vehicle and the control to be operated safely in any driving condition.
- Do not attempt to activate or control this device in a hazardous driving situation.
- This product contains either strobe light(s), halogen light(s), high-intensity LEDs or a combination of these lights. Do not stare directly into these lights. Momentary blindness and/or eye damage could result.
- Use only soap and water to clean the outer lens. Use of other chemicals could result in premature lens cracking (crazing) and discoloration. Lenses in this condition have significantly reduced effectiveness and should be replaced immediately. Inspect and operate this product regularly to confirm its proper operation and mounting condition. Do not use a pressure washer to clean this product.
- It is recommended that these instructions be stored in a safe place and referred to when performing maintenance and/or reinstallation of this product.
- **FAILURE TO FOLLOW THESE SAFETY PRECAUTIONS AND INSTRUCTIONS COULD RESULT IN DAMAGE TO THE PRODUCT OR VEHICLE AND/OR SERIOUS INJURY TO YOU AND YOUR PASSENGERS!**

**For warranty information regarding this product, visit [www.whelen.com/warranty](http://www.whelen.com/warranty)**

**IMPORTANT! The lightbar should be located a minimum of 16" from any radio antennas!**

**Permanent Mounting:**

1. Locate the mounting foot and mounting plate included with your lightbar. If not already present, install the mounting plate onto the mounting foot. When properly positioned, this plate is centered from side-to-side on the mounting foot.
2. Flip the lightbar upside-down to expose the bottom of the extrusion and place the mounting foot onto the extrusion.
3. Rotate the mounting foot 90° in a counter-clockwise direction. Make sure that the edges of the mounting foot swing into position under the extrusion mounting lip.
4. Repeat this procedure for the remaining mounting foot and return the lightbar to its right side-up position.
5. Position the lightbar onto the vehicle roof in the desired mounting location. One often selected location is directly above the B-pillars. This area is the strongest part of the roof. Refer to your lightbar manual for cable exit location, to be sure that the lightbar is facing the proper direction.
6. Adjust the two mounting feet outwards so that they are as close to the edge of the roof as possible. Make sure that both mounting feet are in full contact with the roof. Be sure that there is no less than 1/2" clearance between the roof and the lightbar at their closest point. When the mounting feet are in their proper position, lightly tighten the mounting foot allen head set screws.
7. Turn the lightbar upside down and firmly tighten all of the set screws from step 6 (2 or 4 per side).
8. On the mounting foot, remove either the two outer or inner rubber mounting pads. Carefully remove the mounting pad's guide dart so the hole through the center of the pad is exposed then replace the pad (standard foot only). On the adjustable foot, use the hole in the pad as a guide to drill the two holes into the mounting foot.

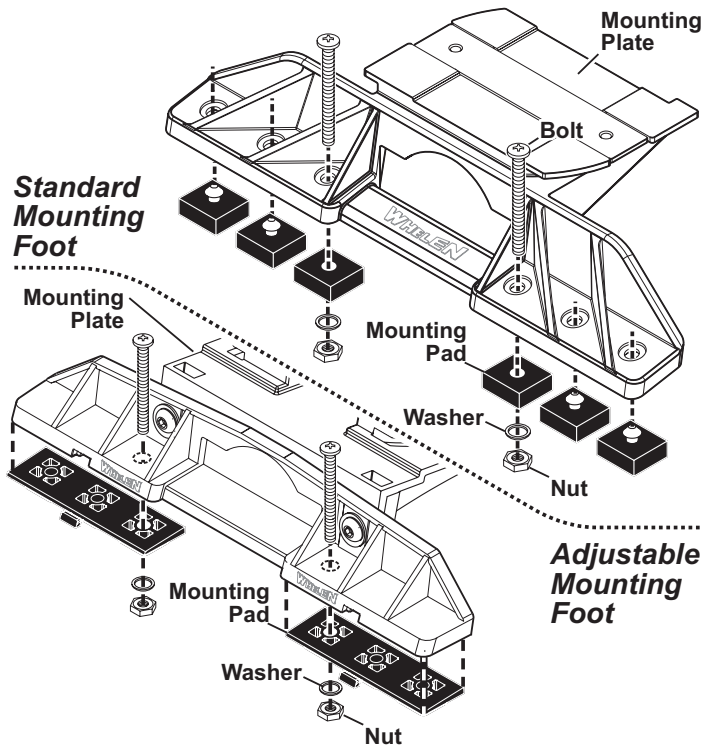

9. Place the lightbar in its final mounting position on the vehicle, mark the mounting hole locations off onto the mounting surface, remove the lightbar and drill the mounting holes.
10. Place the lightbar back onto the vehicle lined up with the mounting holes and secure the mounting feet to the vehicle using the supplied hardware as shown.

**Strap Mounting:**

1. Locate the mounting foot, mounting plate and tinnerman plate included with your lightbar. If not already present, install the mounting plate onto the mounting foot. When properly positioned, this plate is centered from side-to-side on the mounting foot.

2. Flip the lightbar upside-down to expose the bottom of the extrusion and place the mounting foot onto the extrusion.
3. Rotate the mounting foot 90° in a counter-clockwise direction. Make sure that the edges of the mounting foot swing into position under the extrusion mounting lip. Install a tinnerman plate onto the extrusion in the same manner.

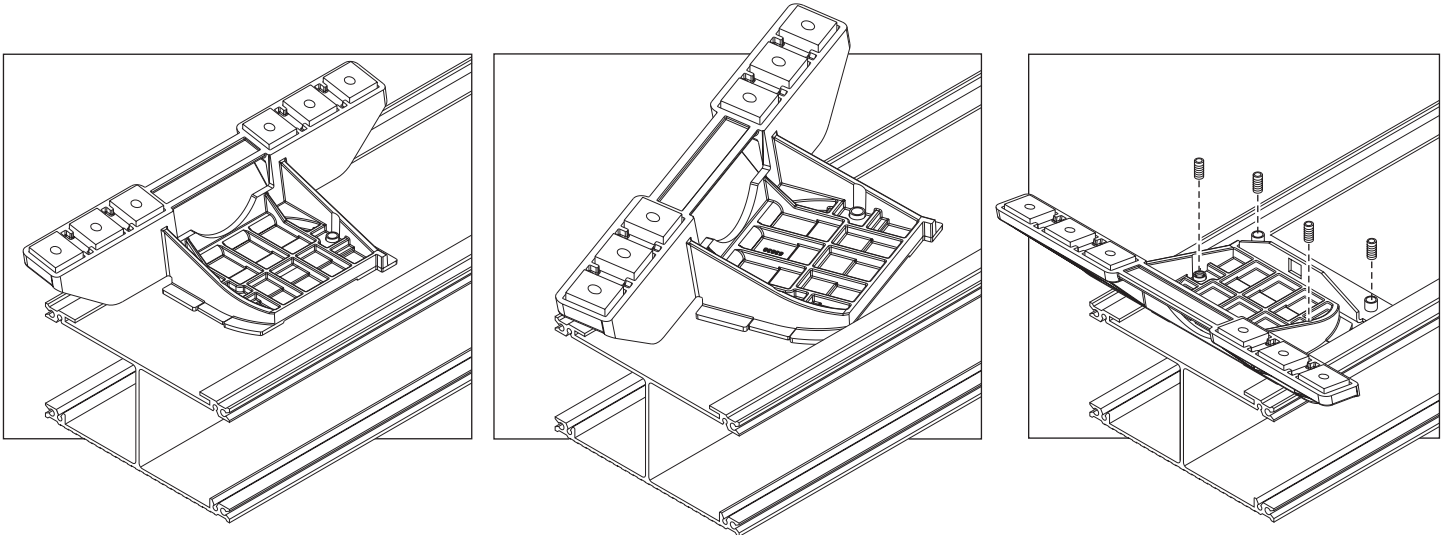

- Repeat this procedure for the remaining mounting foot and tinnerman plate and return the lightbar to its right side-up position.
- Position the lightbar onto the vehicle roof in the desired mounting location. One often selected location is directly above the B-pillars. This area is the strongest part of the roof. Refer to your lightbar manual for cable exit location, to be sure that the lightbar is facing the proper direction.
- Adjust the two mounting feet outwards so that they are as close to the edge of the roof as possible. Both mounting feet must be in full contact with the roof. Be sure that there is no less than 1/2" clearance between the roof and the lightbar at their closest point. When the mounting feet are in their proper position, lightly tighten the mounting foot allen head set screws.
- Return the lightbar to an upside down position. Slide each tinnerman plate outwards until it is fully engaged with its corresponding mounting foot. With the mounting feet and tinnerman plates in their proper positions firmly tighten all of the set screws (2 or 4 per side). Flip the lightbar right side-up and return it to its mounting position.
- Open both drivers side doors. In the area directly below the mounting foot, carefully pull the drivers side weatherstrip away from the vehicle.

- Remove enough so that the area where the mounting strap will be secured to the vehicle is exposed. Repeat procedure for passenger side.
- Insert the mounting strap through the mounting foot. Be sure that the strap fits flush against the area where it will be secured onto the vehicle. Insert the tension bolt through the mounting strap and into the tinnerman nut on the tinnerman plate. Tighten slightly with a long shafted, Phillips screwdriver. Repeat procedure for passenger side.
- If your mounting strap has mounting holes in the end of the strap, use these holes as a template to drill appropriately sized pilot holes through the strap and into the vehicle. Repeat for passenger side of the vehicle.
- Firmly tighten the tension bolts to secure the lightbar to the vehicle.

**NOTE: Model MKAJ is an adjustable mounting foot. On this model you may loosen the screws on the rear of the foot and adjust the angle of the lightbar. This feature can be used if the angle of the roof is not level with the road.**

**IMPORTANT: To adjust the leveling screws you must use a torque wrench set at 35 to 40 in./lbs.**

### Standard Mounting Foot / Model MKEZ

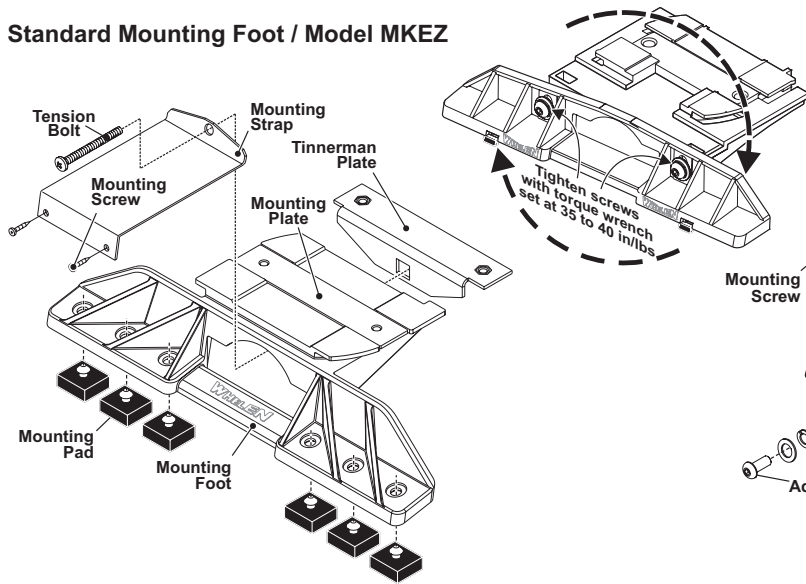

### Adjustable Mounting Foot / Model MKAJ

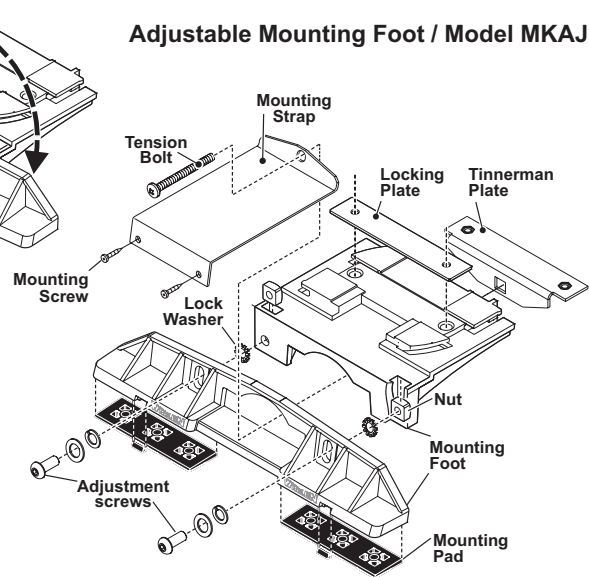

### 5" Mounting Foot

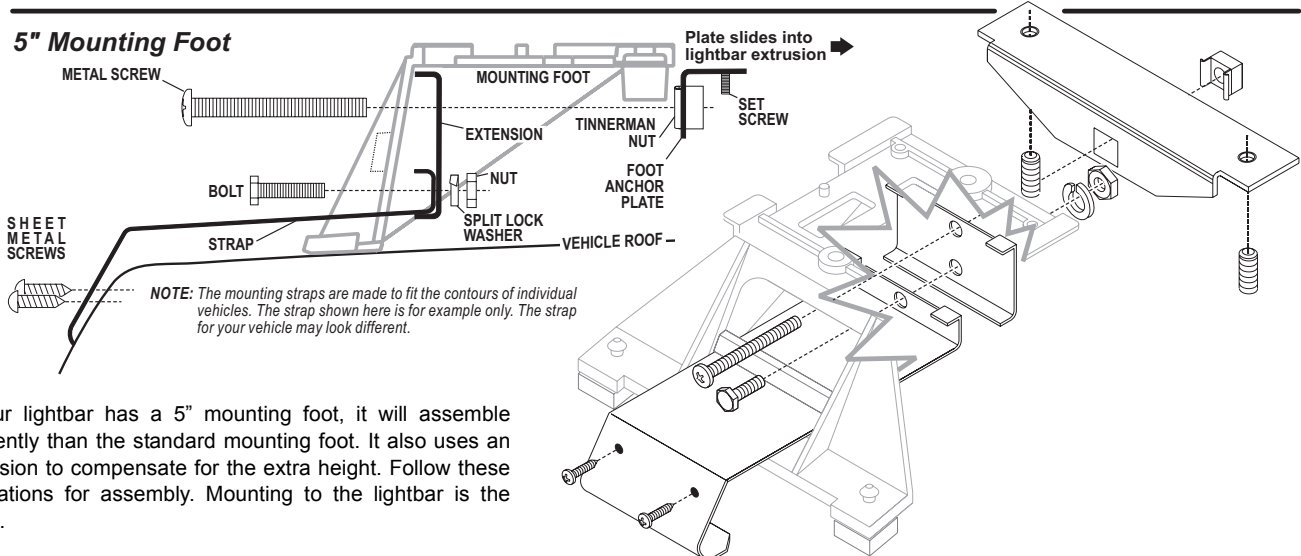

If your lightbar has a 5" mounting foot, it will assemble differently than the standard mounting foot. It also uses an extension to compensate for the extra height. Follow these illustrations for assembly. Mounting to the lightbar is the same.



**NOTE: Unless otherwise specified, the lightbar mounting feet must be sitting as close to the edge of the roof as possible. They must also be in full contact with the roof and not be hanging off the edge.**

**IMPORTANT: For strap mounted bars, be sure you have the right sized lightbar for your vehicle. The lightbar should be approximately the same width as the vehicle roof. If too large or small it will not mount properly to the vehicle and may come loose during driving.**

### Routing your Edge® Lightbar Cable(s)

1. To protect the headliner from damage caused by drilling the cable access hole through the vehicle roof, allow a 5" to 7" distance between roof and headliner by lowering the headliner before drilling.
2. Using a 1" hole saw, drill the cable access hole.

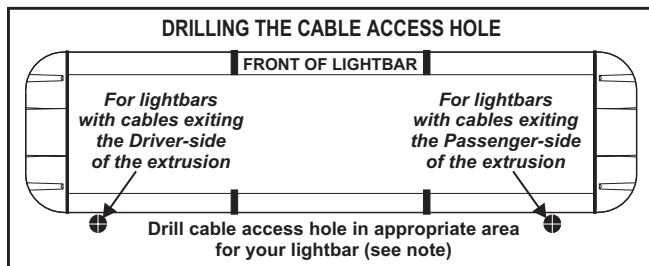

**NOTE:** There may be a roof support member that spans the distance between the driver's and passenger's side. **DO NOT DRILL THROUGH THIS MEMBER!** Adjust the location until the hole can be drilled without contacting this support member.

3. Use a round file to smooth and de-burr the edges of the hole.
4. Insert a 1" grommet (user supplied) into the cable access hole.
5. Insert the cable(s) through the cable access hole into the vehicle. Use RTV silicone to weatherproof the access hole after the cable(s) are pulled completely into the vehicle.
6. Route the cable(s) one at a time to their respective destinations (power cable to vehicle battery; control cable to customer switch panel). It is left to the installation technician's discretion to select a path for these cables that will both protect the cables from possible damage and not interfere with the operation of any other vehicle components or equipment. Refer to the instructions included with your switches for switch wiring information.

**NOTE:** The outer surfaces of this product may be cleaned with mild soap and water. Use of any other chemicals may void product warranty. Do not use a pressure washer.

### Connecting the Cables

**WARNING!** All customer supplied wires that connect to the positive terminal of the battery must be sized to supply at least 125% of the maximum operating current and **FUSED** at the battery to carry that load. **DO NOT USE CIRCUIT BREAKERS WITH THIS PRODUCT!**

### Power Cable:

1. Follow the factory wiring harness through the firewall. It may be necessary to drill a hole in the firewall. If so, be absolutely sure that there are no components that could be damaged by drilling. After the hole has been drilled, insert a grommet to protect the cable.
2. Route the cable along the factory wiring harness towards the battery. Install a 40 amp fuse block (customer supplied) on the end of the RED wire in the power cable. Remove the fuse from the fuse block before connecting any wires to the battery.
3. Connect the fuse block to the POSITIVE (+) terminal on the battery. There can not be more than two (2) feet of wire between the fuse block and the battery. The wire between the fuse block and the battery is "unprotected", do not allow this wire to come into contact with any other wires.
4. Connect the BLACK wire to the factory chassis ground adjacent to the battery.

### Control Cable:

Extend the control cable to your switch panel and make the appropriate connections, using the information provided on pages 4 or 5, depending on which lightbar you have. *When you apply +12 VDC to a Control Cable wire, you activate its function.* The control cable connects to your control head or switch box and is fused there. Typical fusing is 5 Amps.

**NOTE:** The wire functions listed in this manual are the factory default settings for a fully loaded lightbar. To find the correct wire functions for the lightbar you ordered, refer to the switch operations sheet included with your lightbar.

### Troubleshooting:

Your lightbar should now be fully operational. If your lightbar is not functioning properly, check the following:

- The positive wire (RED) is properly connected to the battery, by way of the user supplied fuse block.
- A working fuse of the correct amperage (40 amp) is installed in the fuse block.
- The ground wire (BLACK) is properly connected to the factory ground.

If these connections are good, contact your Whelen representative for further assistance.

## Changing Flash Patterns without a Scan-Lock™ Cable:

The 9M lightbar is capable of displaying a variety of flash patterns. These patterns can be changed at the users discretion using one of two different methods. The first (and easiest) is through the use of the optional Scan-Lock™ pattern cable. Because this allows the user to change patterns from within the vehicle, this method is preferred by customers who want to change their flash patterns when the need arises.

For users who rarely or infrequently change patterns and therefore do not require a Scan-Lock™ cable, it is necessary to partially disassemble the lightbar so as to change patterns manually.

**WARNING! THIS PROCEDURE REQUIRES THE LIGHTBAR TO BE ACTIVE WHILE IN A PARTIALLY DISASSEMBLED STATE. DO NOT TOUCH ANY LIGHTBAR COMPONENTS EXCEPT FOR THOSE REFERENCED IN THIS PROCEDURE.**

1. Notice where the cable enters the bottom of the extrusion. If it enters on the driver side of the extrusion, the Power Distribution Board will be facing the rear of the vehicle. If it enters on the passenger side, it will be facing the front of the vehicle.
2. Remove the endcap nearest to the cable entry. On the appropriate side (front or rear) of the lightbar, remove lenses and move lightheades away from the extrusion until clear access to the Power Distribution Board has been gained.

**Note: Be sure to record the exact position of each component to ensure proper re-assembly.**

3. **Changing Strobe Lighthead Patterns** - Locate the 3-position connector indicated below. As shown, each of the three sockets control pattern selection for each of the lightbar's three strobe power supplies (PS:A, PS:B and PS:C). In the default configuration, the corner strobes use Power Supply A, the inboard strobes use Power Supply B and the end strobes use Power Supply C. Activate the strobe lightheades that are to receive the new flash pattern. Momentarily applying +12VDC to the appropriate socket will cycle that power supply's current flash pattern to the next flash pattern. Repeat this procedure until the desired pattern is displayed. Allowing this pattern to flash for a minimum of 5 seconds will make this pattern the default pattern.
4. **Changing Halogen Lighthead Patterns** - Locate the 4-position connector on the appropriate halogen flasher (A or B). As shown, the socket located in position 4 controls pattern selection for the halogen lightheades connected to that flasher. Momentarily applying +12VDC to this socket will cycle that halogen flasher's current flash pattern to the next flash pattern. Repeat this procedure until the desired pattern is displayed. Allowing this pattern to flash for a minimum of 5 seconds will make this pattern the default pattern.
5. **Restoring the Factory Default Pattern** - To restore the factory default flash pattern, make sure that the lightheades to be restored are off. For strobe lightheades, apply +12VDC to the appropriate socket (see strobe lighthead procedure above) while powering up the corresponding lightheades. Allow pattern to be displayed for a minimum of 5 seconds to make this the default pattern.

For halogen lightheades, use the same procedure as outlined for strobe lightheades, substituting the halogen selection socket(s) where the strobe socket is referenced. Allow pattern to be displayed for a minimum of 5 seconds to make this the default pattern.

**Power Distribution Board**

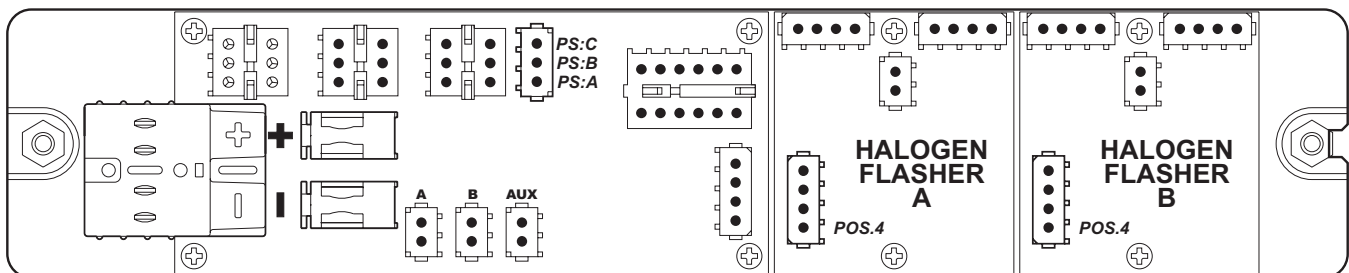

**EDGE® 9M SERIES LIGHTBAR**

Apply +12VDC to a control wire to enable that function. The control cable connects to your control head / switch box and is fused there. Typical fusing is 5 Amps.

- GREEN - In the factory default configuration, this wire activates *Front Corner Strobes*
- BLUE - In factory default configuration, this wire activates *Rear Corner Strobes*
- GREEN/WHITE TRACE - In factory default configuration, this activates *Front Inboard Strobes*
- BLUE/WHITE TRACE - In factory default configuration, this activates *Rear Inboard Strobes*
- GREEN/BLACK - In factory default configuration, this activates *Front Outboard Strobes*
- BLUE/BLACK - In factory default configuration, this activates *Rear Outboard Strobes*
- VIOLET - This will initiate low power operation of all strobes (*See: Low Power Violet*)
- YELLOW - In factory default configuration, this activates *Passenger Alley Light*
- WHITE - In factory default configuration, this activates *Driver Alley Light*
- WHITE/ORANGE - In factory default configuration, this activates *9MTD2 Take-Down Lights\* (or Aux. Lights)*
- WHITE/BLACK - In factory default configuration, this activates *9MH2 Take-Down Lights\* (not used if 9MTD2 is present)*
- WHITE/BROWN - In factory default configuration, this activates *Flasher "A" \**
- WHITE/GREEN - In factory default configuration, this activates *Flasher "B" \**
- WHITE/YELLOW - In factory default configuration, this activates *Flashing Take-Downs\* (not used if 9MTD2 is present)*
- WHITE/BLUE - In factory default configuration, this activates *Work Lights\**
- NONE - RFI shield drain wire; connect to Ground
- WHITE/VIOLET - In factory default configuration, this activates *Flashing Work Lights*
- WHITE/RED - *Not Used*

CONTROL CABLE

POWER CABLE

**MAIN FUSE CHART**

To use the chart below: After determining which function wires you will use, add up the amp rating of each function wire. You must then multiply this by 1.25 (see warning) and fuse the RED power wire at this rating.

<u>WIRE COLOR</u>	<u>FUNCTION</u>	<u>CURRENT DRAW</u>
GREEN	Front Corner Strobes	3 amps
BLUE	Rear Corner Strobes	3 amps
GREEN/WHITE TRACE	Front Inboard Strobes	3 amps
BLUE/WHITE TRACE	Rear Inboard Strobes	3 amps
GREEN/BLACK	Front Outboard Strobe	3 amps
BLUE/BLACK	Rear Outboard Strobe	3 amps
YELLOW	Passenger Alley Light	2.5 amps
WHITE	Driver Alley Light	2.5 amps
WHITE/BLACK	Take-Down Lights	5 amps
WHITE/BROWN	Flasher "A"	5 amps
WHITE/GREEN	Flashers "B"	5 amps
WHITE/ORANGE	Auxiliary Option	5 amps
WHITE/YELLOW	Flashing Take-Downs	2.5 amps
WHITE/BLUE	Work Lights	5 amps
WHITE/VIOLET	Flashing Work Lights	2.5 amps

**EXAMPLE:** Using the WHITE/BLACK, WHITE, & WHITE/ORANGE function wires, the total amp draw is 17.5 amps. Multiply this by 1.25 which comes out to 21.87 amps. You must fuse the RED power wire at 25 amps.

See "Main Fuse Chart" for fuse value

- RED - +12 VDC/8 AWG
- BLACK - Ground/8 AWG
- NONE - RFI Shield Drain

\* = Optional Equipment: May not be present on all Lightbars

**WARNING:** All Customer supplied wires that connect to the positive terminal of the battery, must be sized to supply at least 125% of the maximum operating current and be **FUSED** at the battery to carry the load. **DO NOT USE CIRCUIT BREAKERS WITH THIS PRODUCT!**

**LOW POWER / VIOLET** The type of switch used is dependant on how the operator wishes the Hi/Low feature to function:  
**Latching Mode:** By applying +12 VDC voltage to the Violet wire for less than 1 sec., the power supply is "latched" into low power operation. The unit must be turned off and then back on to restore normal, Hi power operation. (*A Momentary Switch is Preferred*)  
**Level Mode -** Applying +12 VDC voltage to the Violet wire for more than 1 sec. holds the power supply in low power mode until voltage is removed. (*A Toggle Switch is Preferred*)

**EDGE® 9M SERIES LIGHTBAR for MODELS EQUIPPED with STROBE TRAFFIC ADVISOR™**

- GREEN - In the factory default configuration, this wire activates *Front Corner Strobes*
- BLUE - In factory default configuration, this wire activates *Rear Corner Strobes*
- GREEN/WHITE TRACE - In factory default configuration, this activates *Front Inboard Strobes*
- BLUE/WHITE TRACE - In factory default configuration, this activates *Rear Inboard Strobes*
- WHITE/GREEN TRACE - In factory default configuration, this activates *2 Strobe T.A. Flash*
- WHITE/BLUE - In factory default configuration, this activates *4 Strobe T.A. Flash*
- VIOLET - This will initiate low power operation of all strobes *See: Low Power Violet*
- YELLOW - In factory default configuration, this activates *Passenger Alley Light \**
- WHITE - In factory default configuration, this activates *Driver Alley Light \**
- WHITE/ORANGE -In factory default configuration, this activates *9MTD2 Take-Down Lights \* (or Aux. Lights)*
- WHITE/BLACK - In factory default configuration, this activates *9MH2 Take-Down Lights \* (not used if 9MTD2 is present)*
- WHITE/BROWN - In factory default configuration, this activates *Flasher "A" \**
- GREEN/BLACK - In factory default configuration, this activates *Right Traffic Advisor \**
- WHITE/YELLOW - In factory default configuration, this activates *Flashing Take-Downs \* (not used if 9MTD2 is present)*
- BLUE/BLACK - In factory default configuration, this activates *Left Traffic Advisor \**
- NONE - RFI shield drain wire; connect to Ground
- WHITE/RED - *Not Used*

CONTROL CABLE

POWER CABLE

**MAIN FUSE CHART**

To use the chart below, add up the amp rating of each function wire used. You must then multiply this by 1.25 (see warning) and fuse the RED power wire at this rating.

WIRE COLOR	FUNCTION	AMP RATING
GREEN	Front Corner Strobes	3 amps
BLUE	Rear Corner Strobes	3 amps
GREEN/WHITE TRACE	Front Inboard Strobes	3 amps
BLUE/WHITE TRACE	Rear Inboard Strobes	3 amps
WHITE/GREEN TRACE	T.A. / 2 Strobe Flash	3 amps
WHITE/BLUE	T.A. / 4 Strobe Flash	6 amps
YELLOW	Passenger Alley Light	2.5 amps
WHITE	Driver Alley Light	2.5 amps
WHITE/BLACK	Take-Down Lights	5 amps
WHITE/BROWN	Flasher "A"	5 amps
GREEN/BLACK	Right Traffic Advisor	6 amps
WHITE/ORANGE	Auxiliary Option	5 amps
WHITE/YELLOW	Flashing Take-Downs	2.5 amps
BLUE/BLACK	Left Traffic Advisor	6 amps

**EXAMPLE:** Using the WHITE/BLACK, WHITE, & WHITE/ORANGE function wires, the total amp draw is 17.5 amps. Multiply this by 1.25 which comes out to 21.87 amps. You must fuse the RED power wire at 25 amps.

See "Main Fuse Chart" for fuse value

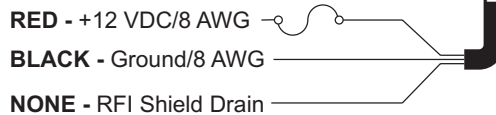

\* = Optional Equipment: May not be present on all Lightbars

**WARNING:** All Customer supplied wires that connect to the positive terminal of the battery, must be sized to supply at least 125% of the maximum operating current and be FUSED at the battery to carry the load. DO NOT USE CIRCUIT BREAKERS WITH THIS PRODUCT!

**LOW POWER / VIOLET** The type of switch used is dependant on how the operator wishes the Hi/Low feature to function:  
**Latching Mode:** By applying +12 VDC voltage to the Violet wire for less than 1 sec., the power supply is "latched" into low power operation. The unit must be turned off and then back on to restore normal, Hi power operation. (A Momentary Switch is Preferred)  
**Level Mode -** Applying +12 VDC voltage to the Violet wire for more than 1 sec. holds the power supply in low power mode until voltage is removed. (A Toggle Switch is Preferred)

Lighthead owners should familiarize themselves with the following component replacement procedures for proper assembly and re-assembly of this product.

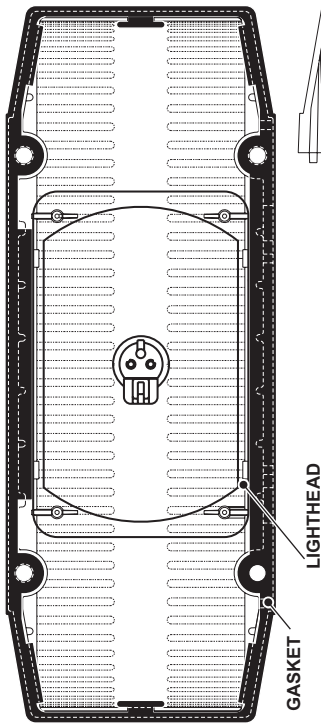

### Installing Endcap Gasket & Alley Light

Place the endcap gasket into position on the endcap, locating all tabs and holes.

Align the reflector assembly of the alley light with the 4 bosses in the endcap and press the reflector in place until the 4 barbs engage around the reflector.

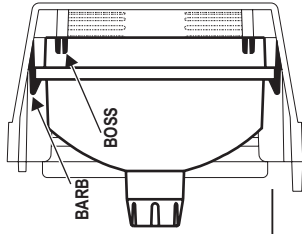

### Removing the Endcap and Lenses

Remove the four screws (A) that hold the endcap (B) on and pull the endcap and gasket (C) off. Slide the lenses (D) out of the lighthead, to gain access to the extrusion. When reinstalling the lenses and spacers, install the cord seal (See below). When reinstalling the endcap, place the endcap gasket into its position on the endcap and line up all the tabs and holes. Spacers (not shown) mount the same as lenses.

#### Seal Cord Installation / NFPA MODELS ONLY:

- 1 - Cut the seal cord approx. 1-1/2" longer than the extrusion on each side.
- 2 - Rub silicone over the cord seal. Leave 3 to 4 inches on one end dry.
- 3 - Beginning with a corner lens, press the lens into the bottom lens track. Place the cord seal into the groove on the top of the lens leaving 1 to 2" free.
- 4 - Hold onto the left end of the seal hanging out and slide the corner lens into position.
- 5 - From the opposite end of the lighthead, pull the seal cord tight and install the remaining lenses and divider.

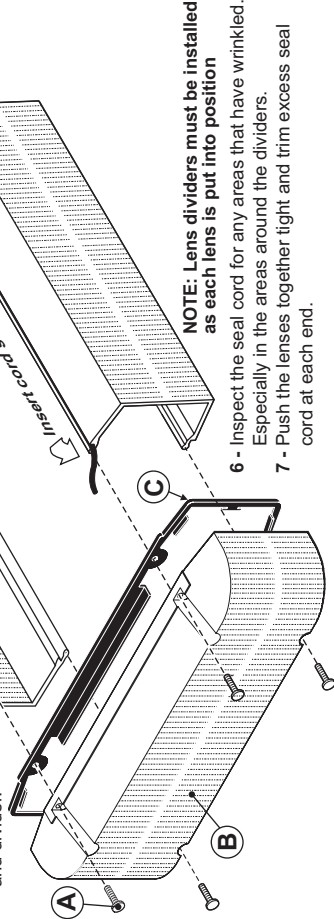

**NOTE: Lens dividers must be installed as each lens is put into position**

- 6 - Inspect the seal cord for any areas that have wrinkled. Especially in the areas around the dividers.
- 7 - Push the lenses together tight and trim excess seal cord at each end.

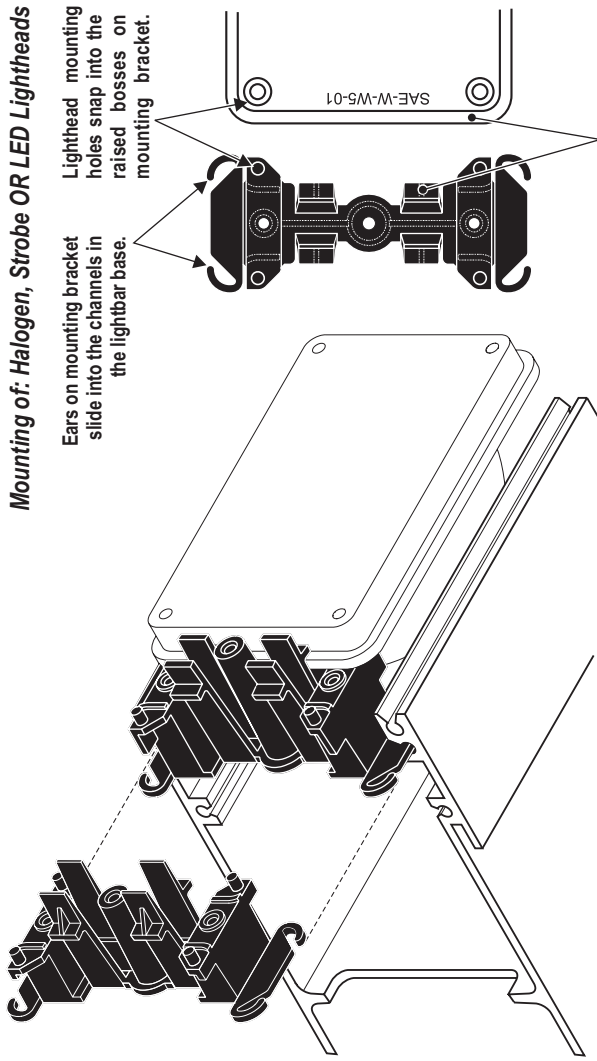

Edge of lighthead snaps into clips on bracket.

### TOP VIEW OF LIGHTBAR BASE

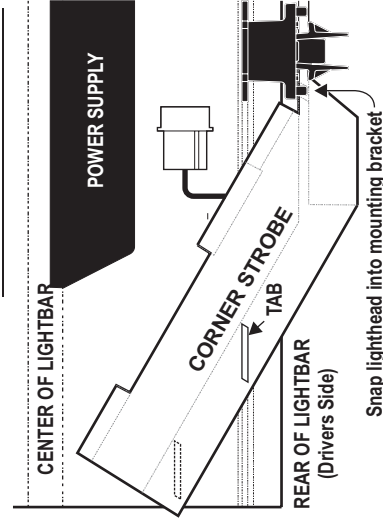

### END VIEW OF LIGHTBAR BASE

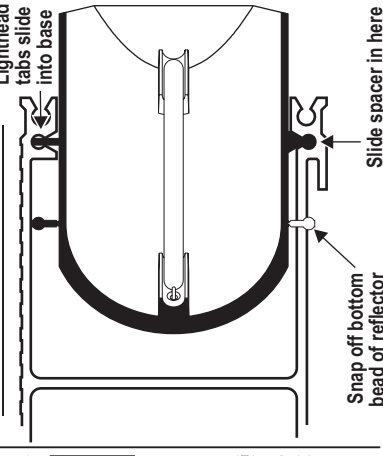

Before working on strobe lights, disconnect the lighthead from power and remove the endcap. **WARNING:** The strobe light power supply is a high voltage device. Do not remove the strobe tubes or dismantle the strobe lightheads in the system while the unit is in operation. Wait 10 minutes after turning off power before working on the system. To remove the lighthead, unplug it from the mounting bracket, unplug it, and slide it out of the side of the lighthead base. If you are replacing the lighthead, snap off the bottom bead on the new lighthead as shown. Plug the new lighthead into the lighthead, slide it into the base and snap it into the mounting bracket.