

WHELEN[®]

ENGINEERING COMPANY INC.

Route 145, Winthrop Road,

Chester, Connecticut 06412

Phone: (860) 526-9504

Fax: (860) 526-4078

Internet: www.whelen.com

Sales e-mail: autosale@whelen.com

Canadian Sales e-mail: autocan@whelen.com

Customer Service e-mail: custserv@whelen.com

Installation Guide: 2022 Series Strobe Beacons (Polycarbonate Base)

Safety First

This document provides all the necessary information to allow your Whelen product to be properly and safely installed. Before beginning the installation and/or operation of your new product, the installation technician and operator must read this manual completely. Important information is contained herein that could prevent serious injury or damage.

- Proper installation of this product requires the installer to have a good understanding of automotive electronics, systems and procedures.
- If mounting this product requires drilling holes, the installer **MUST** be sure that no vehicle components or other vital parts could be damaged by the drilling process. Check both sides of the mounting surface before drilling begins. Also de-burr the holes and remove any metal shards or remnants. Install grommets into all wire passage holes.
- If this manual states that this product may be mounted with suction cups, magnets, tape or Velcro™, clean the mounting surface with a 50/50 mix of isopropyl alcohol and water and dry thoroughly.
- Do not install this product or route any wires in the deployment area of your air bag. Equipment mounted or located in the air bag deployment area will damage or reduce the effectiveness of the air bag, or become a projectile that could cause serious personal injury or death. Refer to your vehicle owners manual for the air bag deployment area. The User/Installer assumes full responsibility to determine proper mounting location, based on providing ultimate safety to all passengers inside the vehicle.
- For this product to operate at optimum efficiency, a good electrical connection to chassis ground must be made. The recommended procedure requires the product ground wire to be connected directly to the **NEGATIVE (-)** battery post (this does not include products that use cigar power cords).
- If this product uses a remote device for activation or control, make sure that this device is located in an area that allows both the vehicle and the device to be operated safely in any driving condition.
- Do not attempt to activate or control this device in a hazardous driving situation.
- This product contains either strobe light(s), halogen light(s), high-intensity LEDs or a combination of these lights. Do not stare directly into these lights. Momentary blindness and/or eye damage could result.
- Use only soap and water to clean the outer lens. Use of other chemicals could result in premature lens cracking (crazing) and discoloration. Lenses in this condition have significantly reduced effectiveness and should be replaced immediately. Inspect and operate this product regularly to confirm its proper operation and mounting condition. Do not use a pressure washer to clean this product.
- It is recommended that these instructions be stored in a safe place and referred to when performing maintenance and/or reinstallation of this product.
- **FAILURE TO FOLLOW THESE SAFETY PRECAUTIONS AND INSTRUCTIONS COULD RESULT IN DAMAGE TO THE PRODUCT OR VEHICLE AND/OR SERIOUS INJURY TO YOU AND YOUR PASSENGERS!**

For warranty information regarding this product, visit www.whelen.com/warranty

Specifications:

Input Voltage.....	12.8 / (25.6) VDC
Input Current.....	2.5 Amps & 1.25 Amps avg.
Input Power.....	31.5 Watts
Flashrate: QuintFlash™.....	72 QuintFlashes™ (5) Per Minute
DoubleFlash.....	115 Double Flashes Per Minute
RapidRandom.....	150-370-150 Flashes Per Minute
ActionFlash™.....	1 QuintFlash™ & 4 Single Flashes Per Minute
Energy.....	8.6 / 2.5 / 2.5 / 2.5 / 2.5 Joules
Output Power.....	22 Watts

WARNING! The strobe power supply is a high voltage device. Do not remove flash tubes or dismantle the strobe light head assembly while in operation. Wait 10 minutes after turning power off before starting work or trouble shooting.

Mounting:

1 Inch (NPT) Pipe Mount:

1. Threading for a 1 inch (NPT) pipe mounting is precast in the base. Feed power cable through pipe and connect cable to beacon.
2. Screw strobe beacon to threads on the pipe, taking precaution not to damage the power wires. **NOTE: Do not tighten base too hard onto pipe so as not to damage the threads on the base.**

Permanent Mount:

1. Use the base as a template and mark the three mounting holes onto the mounting surface. After removing the base, mark in the center between the 3 mounting holes, the location of the wire access hole.
2. Drill the mounting holes using a #16 drill bit. Drill a wire access hole using a 3/8" drill bit. Remove the burrs from the wire access hole so as not to damage the wires. It is recommended that you install a rubber grommet to further protect the wires. A gasket will be used between the beacon base and the mounting surface.
3. After connecting the beacon to the power cable, feed the wires through the cable access hole and place the base with the gasket on the mounting surface, lining up the mounting holes in the base with the mounting holes in the mounting surface. Secure beacon firmly to the mounting surface with the #10 X 5/8 Sheet Metal Screws.

Temporary Mount:

Magnetic/suction: Thoroughly clean the proposed mounting surface prior to mounting. For suction cup mounting, wipe the suction cup clean, place the beacon onto its mounting surface and apply gentle pressure to ensure a good seal. The Magnetic/Suction Cups mount the same way as standard suction cups but are best suited to a flat, steel surface.

Magnetic: Place beacon onto mounting surface and plug into cigar lighter.

WARNING! Beacons equipped with cigar cords are intended for shortduration, intermittent operation only! Prolonged operation requires the beacon to be wired to the vehicle.

WARNING! The presence of any temporarily mounted warning light on the outside of a vehicle in motion is not recommended and is at the sole discretion and liability of the user!

WARNING! All customer supplied wires that connect to the positive terminal of the battery must be sized to supply at least 125% of the maximum operating current and FUSED at the battery to carry the load. **DO NOT USE CIRCUIT BREAKERS WITH THIS PRODUCT!**

DC voltage models are polarity sensitive. If the positive and negative wires are reversed the unit will not function. The fuse is installed between the power source and the beacon, in the positive (+) wire (RED) and must be fused at the battery. A 7.5 AMP Fuse is Recommended for this unit.

1. Connect the RED wire on the beacon to positive voltage (+). A customer supplied single pole single throw (SPST) switch may be used to control the ON-OFF function of the beacon.
2. Connect the BLACK wire on the beacon to a negative (-) ground.

Mirror Mount Bracket

1. Secure the bracket to the mirror or other part of the vehicle using the 2 supplied U-Bolts and elastic stop nuts.
2. Secure the Beacon to the bracket using the supplied sheet metal screws and elastic stop nuts.

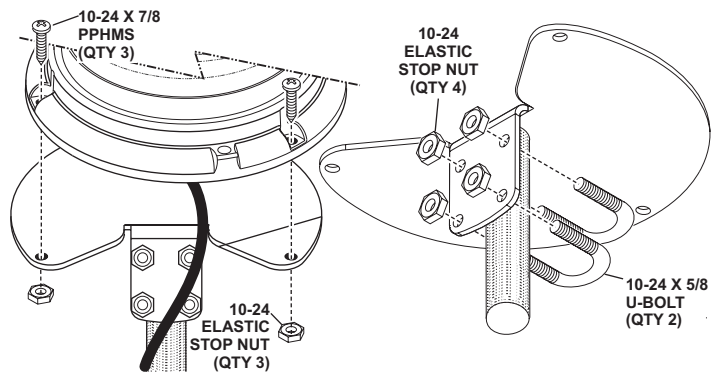

Assembly and Operation:

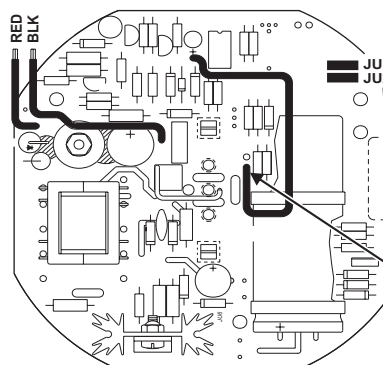

PCB ASSEMBLY (COMPONENT SIDE)

FLASH PATTERNS	JU1	JU2
QuintFlash™	IN	IN
DoubleFlash	IN	CUT
RapidRandom	CUT	IN
ActionFlash™	CUT	CUT

FLASH PATTERN SELECTION
To achieve any of the 4 flash patterns, you must either cut-out or leave-in one, two, both or neither of the two jumpers. If you do not touch the jumpers the beacon will default to QuintFlash™.

HIGH/LOW POWER CONTROL
If you wish to control High/Low Power externally, cut the VIOLET wire off at this point and exit with the BLACK and RED wires. Ground this wire to go to high power. You may install an SPST switch (customer supplied).

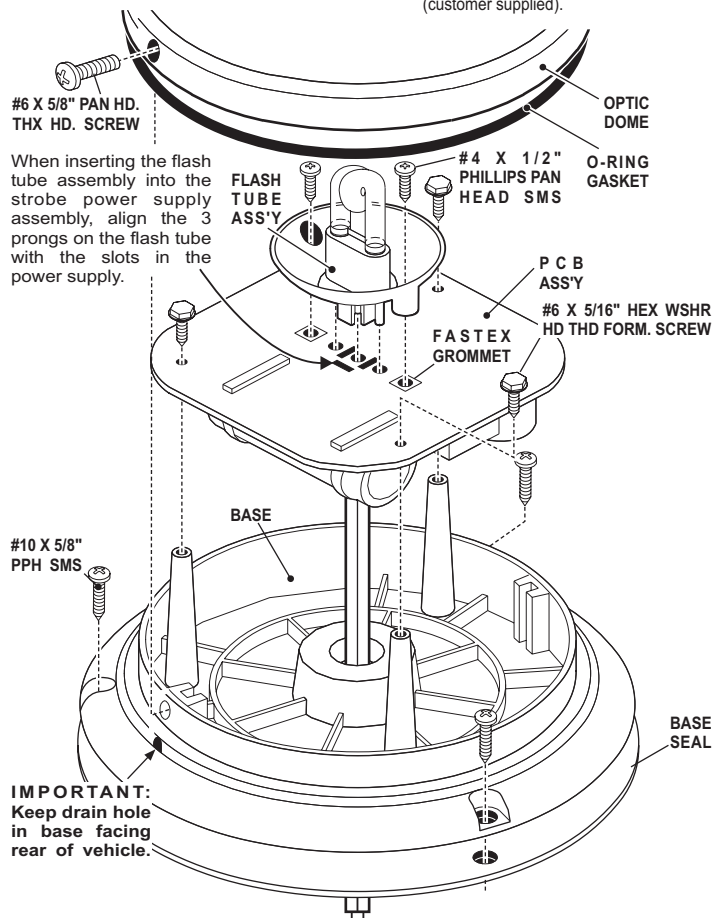

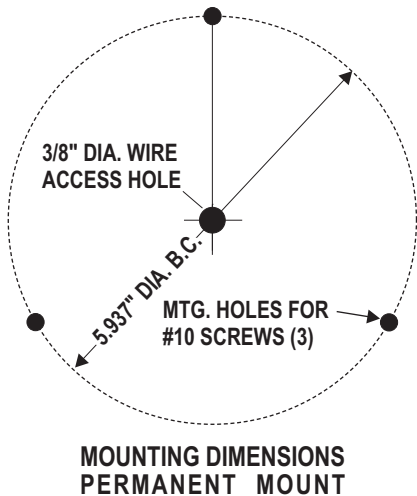
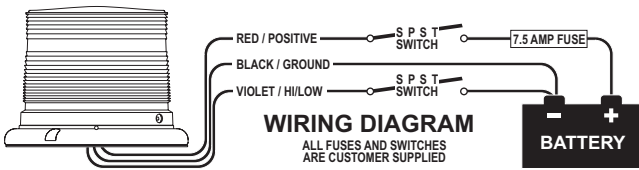
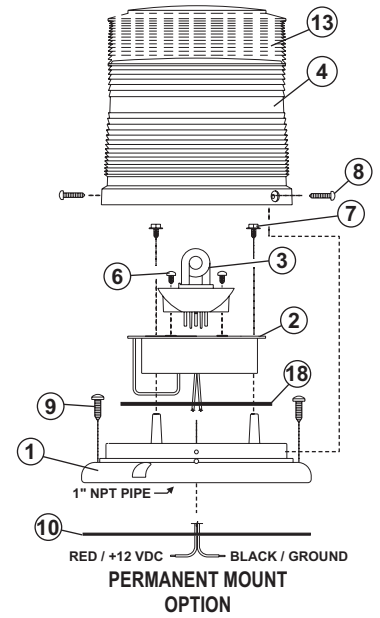
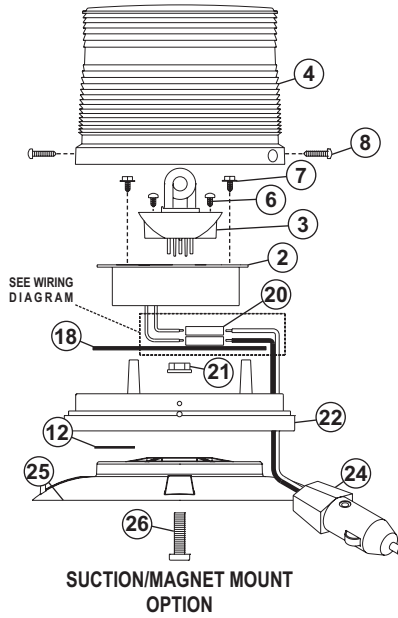
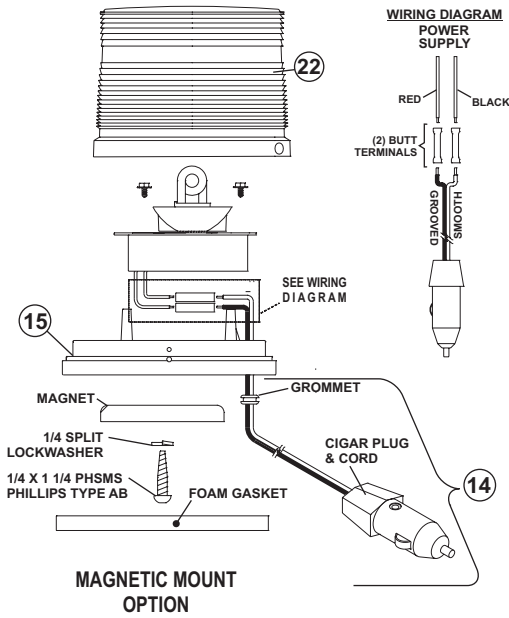

STROBE LIGHT BEACON / MODEL 2022 / PARTS

PART NO. KEY: BASIC PART NUMBER + 3 LETTERS

DOME: H - HIGH DOME L - LOW DOME

COLOR: R - RED B - BLUE G - GREEN A - AMBER C - CLEAR V - VIOLET

BASE: P - PERM MOUNT M - MAGNETIC MT. V - VACUUM MT.

01-0683147

QTY	QTY	QTY	QTY	ITEM	PART NUMBER	DESCRIPTION
		*			01-0683147LAP	STROBE LIGHT ASSY / MODEL 2022LP
		*			01-0683147HAP	STROBE LIGHT ASSY / MODEL 2022HP
		*			01-0683147LAM	STROBE LIGHT ASSY / MODEL 2022MP/VP422MP
*					01-0683147LAV	STROBE LIGHT ASSY / MODEL 2022LV
-	-	1	1	1	06-181468-001	BASE / STROBE / PLASTIC
1	1	1	1	2	02-0168306-00	PCB ASSY / MODEL 2022 SERIES
1	1	1	1	3	36-0341567-00	FLASH TUBE ASSY / FTU 20W
1	1	-	1	4	68-2180452-10	DOME / AMBER
2	2	2	2	6	15-041416-080	#4 X 1/2" PHILLIPS PAN HD SMS SS
3	3	3	3	7	15-066939-056	#6 x 5/16" HEX WASHR HD. THD. FORMING SCREW
2	2	2	2	8	15-065410-100	#6 X 5/8" PAN HD. THD. FORM SCREW
-	-	3	3	9	15-101416-100	#10 x 5/8" PPH SHEET METAL SCREW
-	-	1	1	10	38-0241596-00	SEAL-BASE / MODEL 2000 SERIES B
-	-	1	-	13	68-2180483-10	DOME / AMBER / HIGH
1	1	-	-	14	01-0461585-00	KIT / MAGNET MOUNT / 2000 SERIES B
-	1	-	-	15	06-182589-001	BASE / STROBE / PLASTIC / MAG. MT.
1	1	1	1	18	38-0441331-00	O-RING / ROTATING BEACON ASSEMBLY
2	-	-	-	20	25-0510523-05	BUTT TERMINAL #34071
1	-	-	-	21	13-130111-073	1/4-20 WIZ CAD PLATED NUT
1	1	1	1	22	06-143328-000	BASE / VACUUM MOUNT STROBE LIGHT ASSY
1	-	-	-	24	69-1340052-00	CIGAR CORD / PORTABLE
1	-	-	-	25	08-1583927-05	SUCTION CUP / MAGNET SUCTION CUP MOUNT
1	-	-	-	26	14-130216-160	1/4-20 X 1" PPHMS SS SCREW