

WHELEN[®]

ENGINEERING COMPANY INC.

Route 145, Winthrop Road,
Chester, Connecticut 06412

Phone: (860) 526-9504

Fax: (860) 526-4078

Internet: www.whelen.com

Sales e-mail: autosale@whelen.com

Canadian Sales e-mail: autocan@whelen.com

Customer Service e-mail: custserv@whelen.com

Installation Guide: Model PAP112 Power Airhorn *Plus*[™] Amplifier

Safety First

This document provides all the necessary information to allow your Whelen product to be properly and safely installed. Before beginning the installation and/or operation of your new product, the installation technician and operator must read this manual completely. Important information is contained herein that could prevent serious injury or damage.

- **Proper installation of this product requires the installer to have a good understanding of automotive electronics, systems and procedures.**
- **If mounting this product requires drilling holes, the installer MUST be sure that no vehicle components or other vital parts could be damaged by the drilling process. Check both sides of the mounting surface before drilling begins. Also de-burr any holes and remove any metal shards or remnants. Install grommets into all wire passage holes.**
- **If this manual states that this product may be mounted with suction cups, magnets, tape or Velcro[™], clean the mounting surface with a 50/50 mix of isopropyl alcohol and water and dry thoroughly.**
- **Do not install this product or route any wires in the deployment area of your air bag. Equipment mounted or located in the air bag deployment area will damage or reduce the effectiveness of the air bag, or become a projectile that could cause serious personal injury or death. Refer to your vehicle owners manual for the air bag deployment area. The User/Installer assumes full responsibility to determine proper mounting location, based on providing ultimate safety to all passengers inside the vehicle.**
- **For this product to operate at optimum efficiency, a good electrical connection to chassis ground must be made. The recommended procedure requires the product ground wire to be connected directly to the NEGATIVE (-) battery post.**
- **If this product uses a remote device to activate or control this product, make sure that this control is located in an area that allows both the vehicle and the control to be operated safely in any driving condition.**
- **Do not attempt to activate or control this device in a hazardous driving situation.**
- **It is recommended that these instructions be stored in a safe place and referred to when performing maintenance and/or reinstallation of this product.**
- **FAILURE TO FOLLOW THESE SAFETY PRECAUTIONS AND INSTRUCTIONS COULD RESULT IN DAMAGE TO THE PRODUCT OR VEHICLE AND/OR SERIOUS INJURY TO YOU AND YOUR PASSENGERS!**

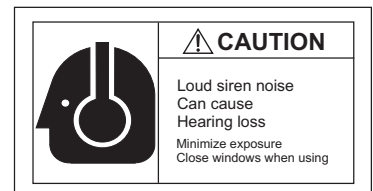

For warranty information regarding this product, visit www.whelen.com/warranty

The *Power Airhorn Plus™* Amplifier, like all Whelen components, can be installed in many different types of vehicles. The guidelines for the installation of this product are written so that no matter what vehicle is being used, the installation and operation will be simple and straight forward.

Selecting a Mounting Location...

The most common choice for a mounting area would be a trunk or similar compartment. However, due to the wide variety of vehicles onto which this unit can be installed, this is not always possible. The following guidelines will help you select an acceptable alternative:

- A) The unit should be mounted on a metal surface to aid heat dissipation. Be sure that this surface is not one that either generates or is exposed to excessive heat during normal operation of the vehicle.
- B) Do not select a location where the unit will be exposed to potential damage from any unsecured or loose equipment in the vehicle.
- C) Be sure the area selected will not allow the unit to be exposed to water!
- D) When routing the wires, it is important to choose a path that will keep these wires away from excessive heat and from any vehicle equipment that could compromise the integrity of the wires (ex. trunk lids, door jams, etc.).
- E) When the best mounting location has been determined, securely fasten the unit to its mounting surface using the supplied hardware.

Caution: As it will be necessary to drill holes into the mounting surface, the installer MUST be sure that no vehicle components or other vital parts could be damaged by the drilling process. Check both sides of the mounting surface before drilling begins!

1. Position the unit in its proposed mounting location to ensure that it fits properly. With the unit in place, insert an awl or other suitable tool into the mounting screw area of the unit and scribe the areas that are to be drilled.
2. Remove the unit from its mounting area and, using an appropriately sized drill bit, drill a hole in each of the areas scribed in the previous step.
3. Return the unit to its mounting location and using the supplied screws, mount the unit onto its mounting surface.

Wiring...

Wire the unit as shown in the diagrams on the next page.

NOTE! Although a 10 amp fuse (customer supplied) is required to be used in the fuse block, do not install the fuse until all of the wire connections are completed.

Microphone Volume Control

Microphone volume can be adjusted by first removing the hole cover from the microphone volume port. Under the hole cover you will see the volume adjustment screw. The volume is increased by turning the screw clockwise and decreased by turning the screw counter clockwise. After you adjust the volume replace the hole cover.

SPECIFICATIONS	
INPUT VOLTAGE	12.8 VDC ±20%
I-IN 13.5V	8 AMPS (TYP)
OUTPUT VOLTAGE	34V RMS (MAX)
SPEAKER	100 WATTS @ 11 OHM
CONTROL VOLTAGE	INPUT VOLTAGE
CONTROL CURRENT	125mA (TYP)
PTT CONTROL VOLTAGE	< 1 VOLT
PTT CTRL CURRENT	15mA (TYP)
OPERATING TEMP.	-30°C TO +60°C
OPERATING HUMIDITY	95% NON CONDENSING
STANDBY CURRENT	45 mA

QTY.	ITEM	PART NUMBER	DESCRIPTION
1	1	01-0662842-00	FINAL ASSEMBLY, POWER AIRHORN PLUS™
1	2	01-0268496-00	ELECTRONIC ASSEMBLY, POWER AIRHORN PLUS™
4	2	15-061216-100	6 X 5/8" PHILLIPS FHMS
1	3	11-285373-000	UPS NYLON COVER, BLACK
1	4	46-0725948-00	POWER INPUT CONNECTOR ASSEMBLY
1	5	46-0725950-00	OUTPUT CONNECTOR ASSEMBLY
3	6	11-240979-000	UPS SERIES, HOLE COVER
1	9	43-0146108-00	MIC ASSY W/3 PIN AMP CONNECTOR
*	10	46-0746109-00	15' MICROPHONE EXTENSION CABLE (OPTIONAL)
REF	11	32-0632010012	10 AMP AUTO FUSE
1	12	01-0415718-07	POWER AIRHORN PLUS™, INSTALLATION KIT

Installation Kit Includes: (2) No. 8 X 3/8" PPHSMS, (2) No. 8 X 1-1/4" PPHSMS, (2) No. 8 X 5/8" PPHSMS, (1) Mic. Clip (Hanger), And Items 4, 5, 9 & 10

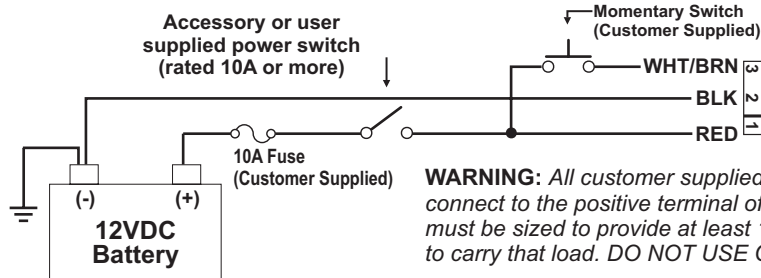
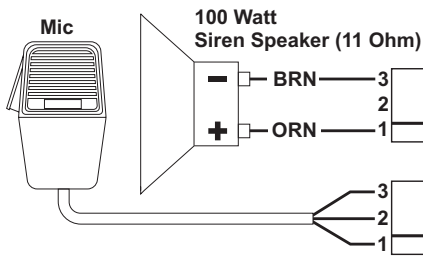
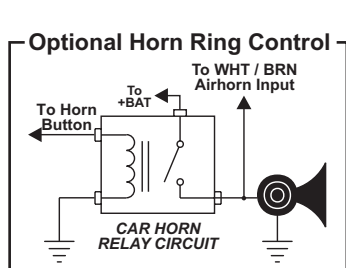
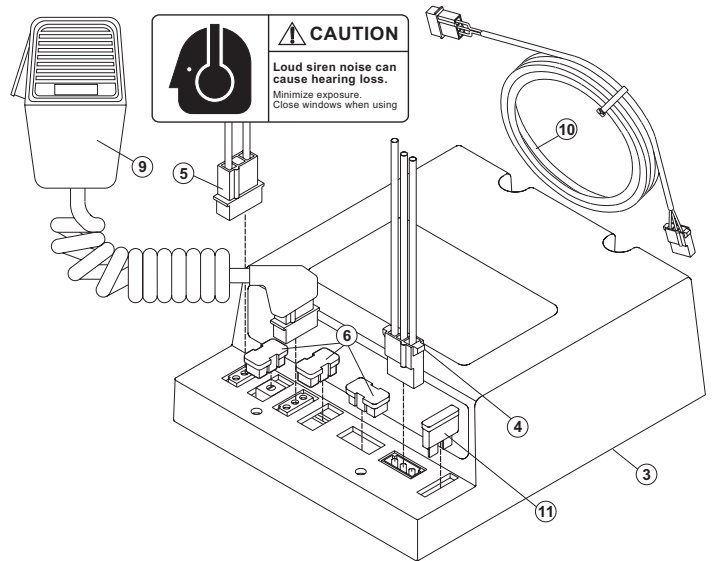

WARNING: All customer supplied wires that connect to the positive terminal of the battery, must be sized to provide at least 125% of the maximum operating current, and fused "at the battery" to carry that load. DO NOT USE CIRCUIT BREAKERS WITH THIS PRODUCT.

TYPICAL WIRING DIAGRAM

