

WHELEN[®]

ENGINEERING COMPANY INC.

51 Winthrop Road
Chester, Connecticut 06412-0684
Phone: (860) 526-9504
Fax: (860) 526-4078
Internet: www.whelen.com
Sales e-mail: autosale@whelen.com
Canadian Sales e-mail: autocan@whelen.com
Customer Service e-mail: custserv@whelen.com

Installation Guide: 800D Series Strobe Beacon

Safety First

This document provides all the necessary information to allow your Whelen product to be properly and safely installed. Before beginning the installation and/or operation of your new product, the installation technician and operator must read this manual completely. Important information is contained herein that could prevent serious injury or damage.

- Proper installation of this product requires the installer to have a good understanding of automotive electronics, systems and procedures.
- If mounting this product requires drilling holes, the installer **MUST** be sure that no vehicle components or other vital parts could be damaged by the drilling process. Check both sides of the mounting surface before drilling begins. Also de-burr the holes and remove any metal shards or remnants. Install grommets into all wire passage holes.
- If this manual states that this product may be mounted with suction cups, magnets, tape or Velcro[®], clean the mounting surface with a 50/50 mix of isopropyl alcohol and water and dry thoroughly.
- Do not install this product or route any wires in the deployment area of your air bag. Equipment mounted or located in the air bag deployment area will damage or reduce the effectiveness of the air bag, or become a projectile that could cause serious personal injury or death. Refer to your vehicle owner's manual for the air bag deployment area. The User/Installer assumes full responsibility to determine proper mounting location, based on providing ultimate safety to all passengers inside the vehicle.
- For this product to operate at optimum efficiency, a good electrical connection to chassis ground must be made. The recommended procedure requires the product ground wire to be connected directly to the **NEGATIVE (-)** battery post (this does not include products that use cigar power cords).
- If this product uses a remote device for activation or control, make sure that this device is located in an area that allows both the vehicle and the device to be operated safely in any driving condition.
- Do not attempt to activate or control this device in a hazardous driving situation.
- This product contains either strobe light(s), halogen light(s), high-intensity LEDs or a combination of these lights. Do not stare directly into these lights. Momentary blindness and/or eye damage could result.
- Use only soap and water to clean the outer lens. Use of other chemicals could result in premature lens cracking (crazing) and discoloration. Lenses in this condition have significantly reduced effectiveness and should be replaced immediately. Inspect and operate this product regularly to confirm its proper operation and mounting condition. Do not use a pressure washer to clean this product.
- It is recommended that these instructions be stored in a safe place and referred to when performing maintenance and/or reinstallation of this product.
- **FAILURE TO FOLLOW THESE SAFETY PRECAUTIONS AND INSTRUCTIONS COULD RESULT IN DAMAGE TO THE PRODUCT OR VEHICLE AND/OR SERIOUS INJURY TO YOU AND YOUR PASSENGERS!**

For warranty information regarding this product, visit www.whelen.com/warranty

The 800D Series Strobe Beacon features a combination base which may be used for either Flange Mount, 1" (NPT) Pipe Mount, Permanent Mount, Magnetic or Magnetic-Suction mount. The threading for a 1 inch (NPT) pipe mounting is precast in the die-cast base.

WARNING! The strobe light power supply is a high voltage device. Do not remove strobe tubes or dismantle strobe light head assemblies in the system while it is in operation. Wait 10 minutes after turning off power before starting work or any trouble shooting.

- **Input Voltage:** 12VDC and 24VDC
- **Input Current:** 2.5A @12.8V and 1.5A @ 25.6V
- **Output Power:** 25 Watts
- **4 Selectable Flash Patterns.**
- **Selectable Manual Hi/Low Intensity Mode.**
- **Automatic Photocell Hi/Low Intensity Mode (Optional).**
- **Flange / Pipe / Permanent / Magnetic-Suction Mounting.**
- **Hi/Off/Low Intensity Switch. (Optional)**
- **4 Pattern Beacon Controller with Diagnostic & Manual Hi/Low Intensity Control. (Optional)**
- **Factory Installed Cruise Light. (Optional)**

Installation: FLANGE MOUNT

1. Using the base gasket as a template, mark the three mounting holes and the center wire access hole onto the mounting surface.
2. Drill holes for the three 10 X 5/8" pan head sheet metal mounting screws. (supplied)

3. Drill the wire access hole using a 1/2" drill. Install a rubber grommet in the wire access hole to protect the wires.

4. Place base gasket on mounting surface aligned with the holes in the mounting surface. After connecting the strobe beacon to the power cable, feed the wires through the wire access hole. Place strobe beacon into proper position and slip mounting collar over the strobe beacon to fit around base of the unit. Align the three holes in the mounting collar with the three mounting holes in the base gasket and mounting surface. Use the three enclosed mounting screws to attach the strobe beacon to the mounting surface.

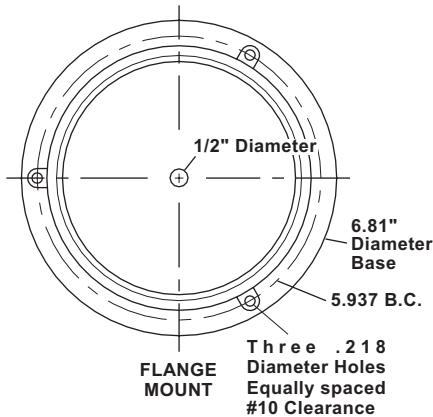

Installation: PIPE MOUNT

1. Feed power cable through the 1 inch pipe and connect the cable to the wires of the 800D Series strobe beacon.
2. Screw the beacon to the threads on the 1 inch pipe, taking precaution not to damage the connected power wires.

Installation: PERMANENT MOUNT

This mounting of the 800D Series strobe beacon is a tamper proof way to secure the unit to the mounting surface. The mounting screws are hidden inside the base, and are not accessible unless the strobe beacon is disassembled.

1. Remove the polycarbonate optic dome from the base (see "Removing Dome & Strobe Power Supply Assembly").

2. Locate the four dimples equally spaced within the perimeter of the die-cast base of the power supply assembly. Punch these dimples out to create a hole for the mounting screws.
3. Using the base of the power supply assembly as a template mark the four mounting holes on the mounting surface. Mark in the center between the four mounting holes the location of the wire access hole.

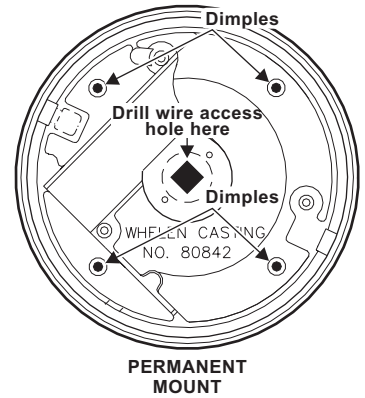

4. Drill mounting holes in the mounting surface to fit customer supplied mounting hardware. Also drill a wire access hole using a 1/2 inch drill. Install a rubber grommet in the wire access hole to protect the wires.
5. Base gasket will be used between the strobe beacon base and the mounting surface. Cut the gasket along perforation to fit the diameter of the base.
6. After connecting the strobe light beacon to the power cable, feed the wires through the cable access hole and place the base with the gasket on the mounting surface, lining up the mounting holes in the base with the ones in the mounting surface. Secure the strobe light beacon base firmly to the mounting surface with customer supplied hardware.
7. Reassemble the strobe light beacon.

Temporary Mounting (Magnetic, Suction Cup, etc.)

With the magnetic or magnetic/suction cup mounting options you will be able to mount your strobe so that you can remove it if necessary and avoid drilling.

Installation: Magnetic/suction

Thoroughly clean the proposed mounting surface prior to mounting. For suction cup mounting, wipe the suction cup clean, place the beacon onto its mounting surface and apply gentle pressure to ensure a good seal has been achieved. The Magnetic/Suction Cups mount the same way as standard suction cups but are best suited to a flat, steel surface.

Installation: Magnetic

Place beacon onto mounting surface and plug into vehicle cigar lighter.

Removing Dome & Strobe Power Supply Assembly:

1. Remove the polycarbonate optic dome from the base by removing the two base screws (Fig. 11).
2. Remove the 3 screws that hold down the strobe power supply assembly and separate it from the base.
3. Remove the spring clip and insulator.

See important information about removing spring clip on next page)

IMPORTANT: Be sure to tape or remove any unused wires.

WARNING! The use of any magnetically mounted warning beacon on the outside of a vehicle while in motion is not recommended and is at the sole discretion and risk of the use

WARNING! Beacons equipped with cigar cords are intended for short duration, intermittent operation only! Prolonged operation requires the beacon to be wired to the vehicle.

WARNING! All customer supplied wires that connect to the positive terminal of the battery must be sized to supply at least 125% of the maximum operating current and FUSED at the battery to carry that load. DO NOT USE CIRCUIT BREAKERS WITH THIS PRODUCT!

Assembly of strobe power supply assembly to die cast base, to ensure prevention of an electrical short circuit between parts:

IMPORTANT: Read all warnings on first page before attempting disassembly of the strobe light power supply and base.

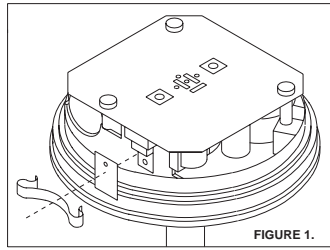

This page describes the assembly procedure of the strobe light power supply to the die-cast base. It is extremely important that the assembly steps, as described below, are precisely followed to insure the proper insulation of the strobe light power supply from the die cast aluminum base.

FIGURE 1. Lower the power supply assembly onto the die-cast base, with the 3 mounting holes lined up with the holes located on the three mounting studs of the cast aluminum base. During this assembly operation, the transistor on the power supply assembly has to be positioned on the outside of the transistor mounting boss. Secure the strobe light power supply assembly to the mounting studs with enclosed self-tapping screws.

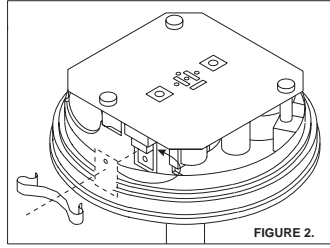
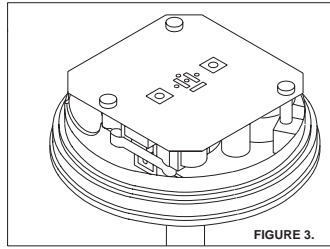

FIGURE 2. Slightly bend the transistor on the power supply away from the transistor mounting boss. Slip the Cho-Therm insulator behind the transistor with the hole directed towards the top (See figure 4"A").



Position the top of the Cho-Therm insulator against the circuit board of the power supply assembly, making sure that some of it shows below the transistor (See figure 4"B"). It is important that the transistor on the power supply assembly does not contact the transistor mounting boss at any place, to prevent a damaging electrical short circuit between the strobe power supply and the die-cast base.

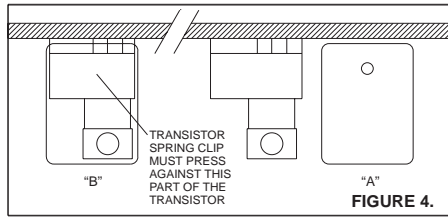
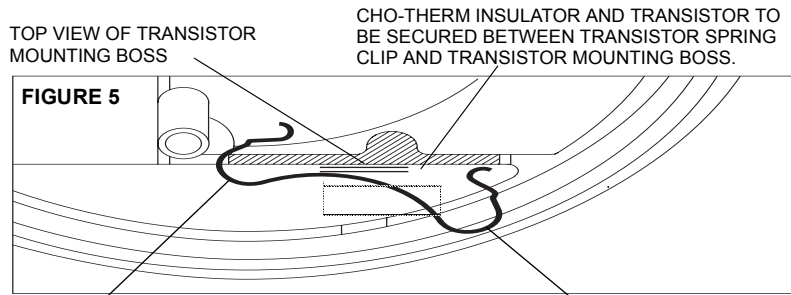
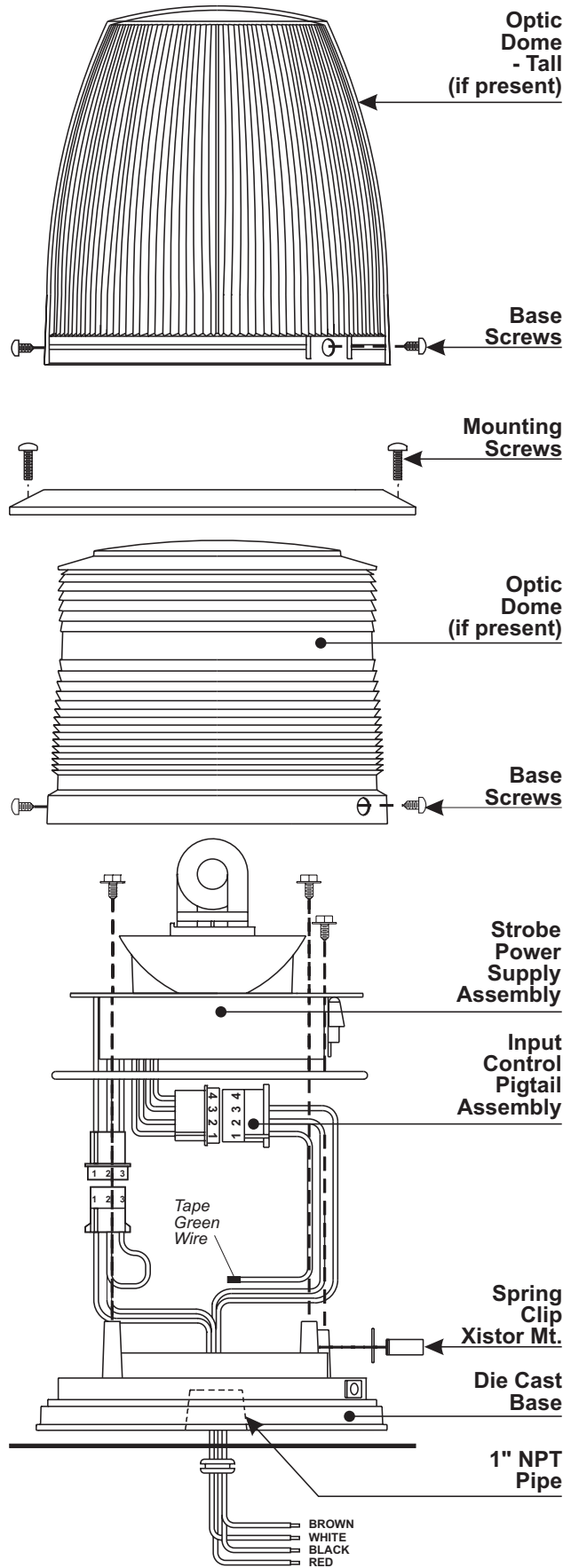

FIGURE 3. Use the transistor spring clip to secure firmly the Cho-Therm insulator and the power supply transistor to the mounting boss of the die-cast base. Wrap one end of the clip around one side of the mounting boss, then press the other end in position using needle nose pliers.



WRAP ONE END OF TRANSISTOR SPRING CLIP AROUND ONE END OF TRANSISTOR MOUNTING BOSS

PUSH OTHER END OF TRANSISTOR SPRING CLIP AROUND OTHER END OF TRANSISTOR MOUNTING BOSS



CUSTOMER OPTIONS

Hi/Low Intensity Option:

1. Take dome and strobe power supply assembly apart. (see "Removing Dome and Strobe Power Supply Assembly")
2. Locate the VIOLET (looped) wire, cut it at pin 2, and run it out of the bottom of the unit with the BLACK and RED wires.
3. Reassemble the unit.
4. Now, if you ground the VIOLET wire, your light will run at high intensity, and if you tape off the VIOLET wire, your light will run at low intensity. You may want to install a two position switch so that you can alternate between the two functions.

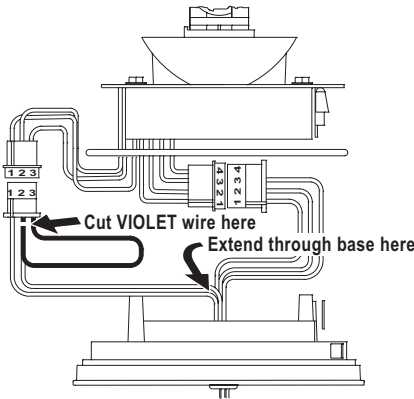

Jumper Options:

There are several options you can utilize by cutting one, both or neither of the jumpers located inside the unit (the jumpers are labeled JU1 and JU2).

- A. You may operate your strobe at either high or low intensity (default setting). Leave both jumpers intact and follow the instructions under "Hi/Low Intensity Option".

- B. Your strobe may also be equipped with the optional "Photocell function". This will automatically adjust the intensity of the strobe light according to the ambient light (darkness switches the beacon to low power, while daylight switches the beacon to high power). To engage this function you must cut the JU2 jumper and leave the JU1 jumper intact. Then clip the VIOLET wire and tape it off (see "Hi/Low Intensity Option"). Now the photocell option is always engaged. If you want to be able to turn this function on or off manually, you must also attach the VIOLET wire to a switch that will ground or disconnect it. When you switch to "ground" the light will always be at high intensity. When you switch to "disconnect" the light will return to the photocell function.

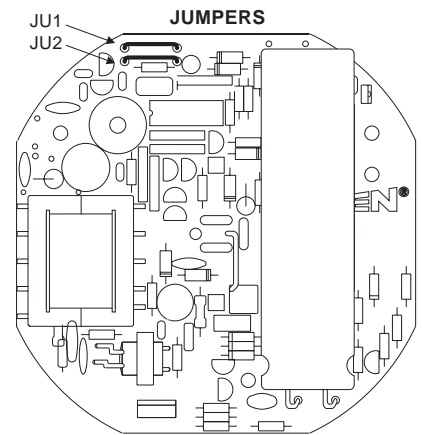

- C. If you want your strobe to turn on automatically during the day and off at night, cut the JU1 jumper and leave JU2 jumper intact.
- D. If you want your strobe to turn off automatically during the day and on at night, cut both the JU1 and JU2 jumpers.

IMPORTANT NOTE: Both "C" and "D" are usually used for remote applications. Once you convert to either of these functions you will not be able use the light any other way.

Flash Pattern Options:

The default flash pattern for the 800D is CometFlash®. You may choose from several other patterns by making a few simple changes.

1. Disassemble the unit as described under "Removing the Dome and Strobe Power Supply Assembly".

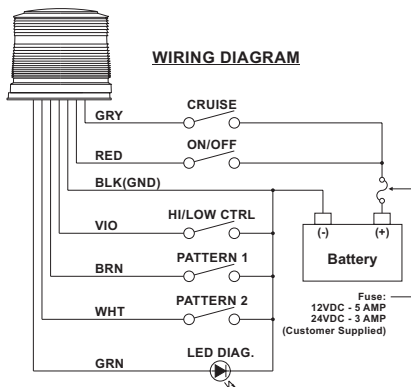

2. Locate the input control pigtail assembly and plug it in to the extra connector coming out of the Power Supply.
3. Run the BROWN & WHITE wires out through the center of the base as shown. Tape off the unused GREEN wire.

4. Reassemble the unit and you are ready to choose your options.

To Select SingleFlash: Ground the WHITE wire and tape off the BROWN wire.

To Select DoubleFlash: Ground the BROWN wire and tape off the WHITE wire.

To Select ActionFlash™: Ground both the WHITE and BROWN wires.

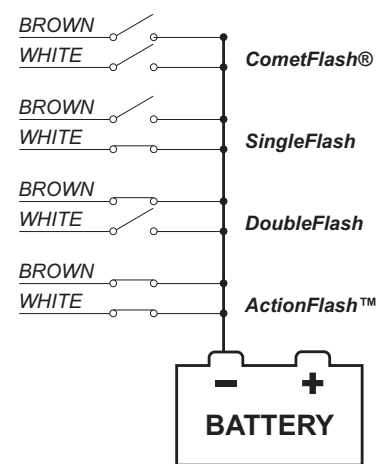

IMPORTANT! Before returning the vehicle to active service, visually confirm the proper operation of this product, as well as all vehicle components/equipment.

Switch control wiring schematics / 800D Strobe Light Series

Switches & fuses are customer supplied. 5 AMP fuse: 12 VDC 3 AMP fuse: 24 VDC.

MODEL 800D STANDARD. ON/OFF SWITCHING / HIGH POWER ONLY.

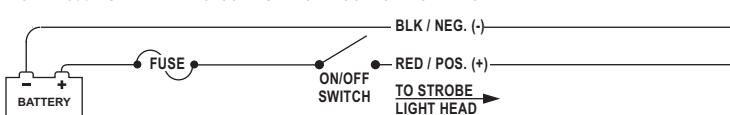

MODEL 800D WITH CRUISE LIGHT OPTION.

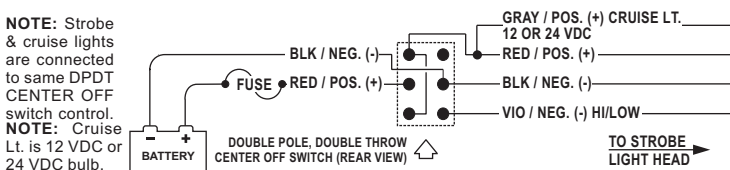

NOTE: Strobe & cruise lights are connected to same DPDT CENTER OFF switch control.
NOTE: Cruise Lt. is 12 VDC or 24 VDC bulb.

MODEL 800D STANDARD. HIGH-OFF-LOW SWITCHING.

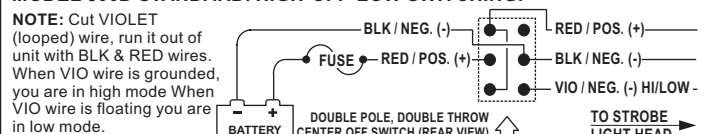

NOTE: Cut VIOLET (looped) wire, run it out of unit with BLK & RED wires. When VIO wire is grounded, you are in high mode. When VIO wire is floating you are in low mode.

MODEL 800D with CRUISE LIGHT OPTION.

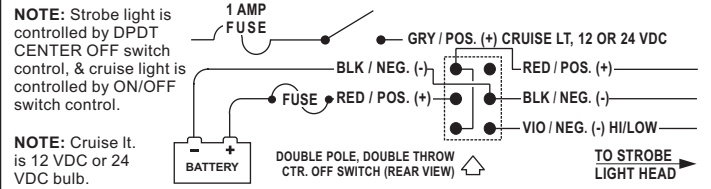

NOTE: Strobe light is controlled by DPDT CENTER OFF switch control, & cruise light is controlled by ON/OFF switch control.
NOTE: Cruise Lt. is 12 VDC or 24 VDC bulb.