

WHELEN[®]

ENGINEERING COMPANY INC.

Route 145, Winthrop Road,
Chester, Connecticut 06412

Phone: (860) 526-9504

Fax: (860) 526-4078

Internet: www.whelen.com

Sales e-mail: autosale@whelen.com

Canadian Sales e-mail: autocan@whelen.com

Customer Service e-mail: custserv@whelen.com

Installation Guide: CSP660 Strobe Power Supply

Safety First

This document provides all the necessary information to allow your Whelen product to be properly and safely installed. Before beginning the installation and/or operation of your new product, the installation technician and operator must read this manual completely. Important information is contained herein that could prevent serious injury or damage.

- **Proper installation of this product requires the installer to have a good understanding of automotive electronics, systems and procedures.**
- **If mounting this product requires drilling holes, the installer MUST be sure that no vehicle components or other vital parts could be damaged by the drilling process. Check both sides of the mounting surface before drilling begins. Also de-burr any holes and remove any metal shards or remnants. Install grommets into all wire passage holes.**
- **If this manual states that this product may be mounted with suction cups, magnets, tape or Velcro™, clean the mounting surface with a 50/50 mix of isopropyl alcohol and water and dry thoroughly.**
- **Do not install this product or route any wires in the deployment area of your air bag. Equipment mounted or located in the air bag deployment area will damage or reduce the effectiveness of the air bag, or become a projectile that could cause serious personal injury or death. Refer to your vehicle owners manual for the air bag deployment area. The User/Installer assumes full responsibility to determine proper mounting location, based on providing ultimate safety to all passengers inside the vehicle.**
- **For this product to operate at optimum efficiency, a good electrical connection to chassis ground must be made. The recommended procedure requires the product ground wire to be connected directly to the NEGATIVE (-) battery post.**
- **If this product uses a remote device to activate or control this product, make sure that this control is located in an area that allows both the vehicle and the control to be operated safely in any driving condition.**
- **Do not attempt to activate or control this device in a hazardous driving situation.**
- **It is recommended that these instructions be stored in a safe place and referred to when performing maintenance and/or reinstallation of this product.**
- **FAILURE TO FOLLOW THESE SAFETY PRECAUTIONS AND INSTRUCTIONS COULD RESULT IN DAMAGE TO THE PRODUCT OR VEHICLE AND/OR SERIOUS INJURY TO YOU AND YOUR PASSENGERS!**

For warranty information regarding this product, visit www.whelen.com/warranty

The CSP660 Strobe Power Supply, like all Whelen components, can be installed in many different types of vehicles. The guidelines for the installation of this product are written so that no matter what vehicle is being used, the installation and operation will be simple.

Selecting a Mounting Location:

The most common choice for a mounting area would be a trunk or similar compartment. However, due to the wide variety of vehicles onto which the CSP660 could be installed, this is not always possible. The following guidelines will help the installer select an alternative:

- **The CSP660 should be mounted on a metal surface to aid heat dissipation. Be sure that this surface is not one that either generates or is exposed to excessive heat during operation of the vehicle.**
- **Do not select a location where the power supply will be exposed to potential damage from any unsecured or loose equipment in the vehicle.**
- **Be sure the area selected will not allow the unit to be exposed to water.**
- **When routing the wires, it is important to choose a path that will keep these wires away from excessive heat and from any vehicle equipment that could compromise the integrity of the wires (ex. trunk lids, door jams, etc.).**
- **When the best mounting location has been determined, securely fasten the CSP660 to its mounting surface using the supplied hardware.**

WARNING!The Strobe Light Power Supply is a high voltage device. Do not touch or remove tube assembly in strobe light head assemblies while in operation. Wait 10 minutes after disconnecting the unit from its power source before starting work or troubleshooting on power supply or system.

CAUTION: As it will be necessary to drill holes into the mounting surface, the installer **MUST** be sure that no vehicle components or other vital parts could be damaged by the drilling process. Check both sides of the mounting surface before drilling begins.

1. Position the unit in its proposed mounting location to ensure that it fits properly. With the CSP660 in place, insert an awl or other suitable tool into the mounting screw area of the power supply and scribe the areas that are to be drilled.
2. Remove the unit from its mounting area and, using a drill bit sized for a #8 phillips pan head sheet metal screws, drill a hole in each of the areas scribed in the previous step.
3. Return the CSP660 to its mounting location and using the supplied #8 phillips pan head sheet metal screws, mount the unit onto its mounting surface.

NOTE: The shorter screws go to the back of the unit.

Wiring your CSP660:

1. Locate the 3 position Power Connector included with your CSP660 and plug it into the port indicated in Fig. 1. Extend the BLACK and RED wires from the Power Connector towards the battery.

WARNING! All customer supplied wires that connect to the positive terminal of the battery must be sized to supply at least 125% of the maximum operating current and FUSED at the battery to carry that load. DO NOT USE CIRCUIT BREAKERS WITH THIS PRODUCT!

2. Connect the RED wire to a fuse block (customer supplied) and then to the POSITIVE terminal on the battery.

NOTE: Although a 10 amp fuse (customer supplied) is required to be used in the fuse block, do not install the fuse until all of the wire connections are completed.

3. Connect the BLACK wire to the factory chassis ground adjacent to the battery.
4. Refer to page 3 for wiring information for the Control Connector and for the Pattern Selection Connector.
5. As indicated in page 3, there is a provision in the Power Connector for a wire (VIOLET) to activate Hi Power/Low Power strobe operation. If this feature is desired, locate the VIOLET wire included with your power supply and, with the Power Connector disconnected from the power supply, insert the pinned end of the VIOLET wire into position 3 of the Power Connector.

CSP660 SPECIFICATIONS	
V-INPUT (DUAL VOLTAGE)	12.8VDC +/-20% 25.6VDC +/-20%
I-IN 12.8V	6 AMPS 3 AMPS
FLASHRATE	150 F/M TYP
FLASH PATTERNS	<ul style="list-style-type: none"> 1 - COMET FLASH 2 - TRIPLE FLASH 3 - DOUBLE FLASH 4 - SINGLE FLASH 5 - ACTION FLASH 6 - MODU-FLASH 7 - MICRO BURST 2 8 - MICRO BURST 3 9 - LONG BURST 10 - ACTIONSCAN
JOULES HI	9.8/4.8/4.8/4.8 TYP
JOULES LO	4.7/2.4/2.4/2.4 TYP
OUTPUT POWER	60 WATTS

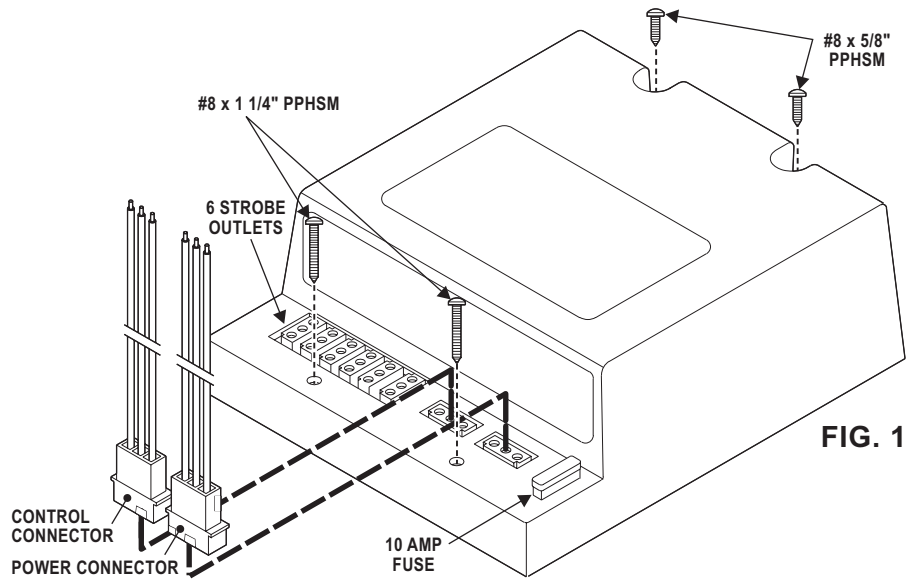

Control Connector	
Position # 1	- Yellow Wire
Position # 2	- Green Wire
Position # 3	- Blue Wire
Power Connector	
Position # 1	- Red Wire
Position # 2	- Black Wire
Position # 3	- Violet Wire / Optional

Pattern Control

To cycle forward to the next pattern: Apply +voltage to Yellow wire for less than 1 second.
 To cycle back to the previous pattern: Apply +voltage to Yellow wire for more than 1 second.
 To establish the active pattern: Allow pattern to flash for more than 5 seconds.

NOTE - The type of switch used depends on how the operator wishes the Hi/Lo feature to function:

Latching Mode: By applying +voltage to the Violet wire for less than 1 sec., the power supply is "latched" into low power operation. The unit must be turned off and then back on to restore normal, Hi power operation. A momentary switch is desired for this style.

Level Mode: Applying +voltage to the Violet wire for more than 1 sec. holds the power supply in low power mode until that voltage is removed. Use a toggle switch for this style.

Wiring Option 1: All Outlets On/Off

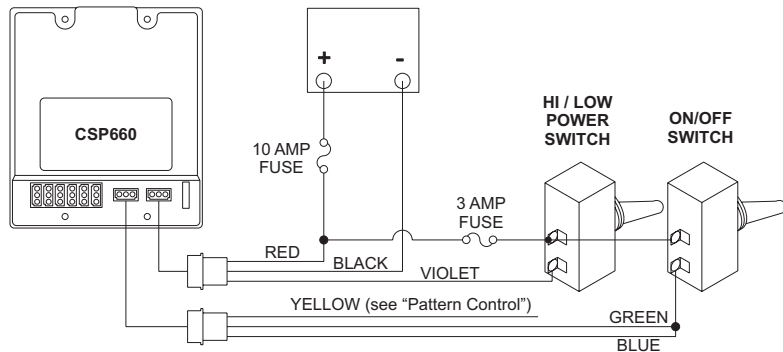

Wiring Option 2: Group Outlet Control

