

# WHELEN<sup>®</sup>

ENGINEERING COMPANY INC.

51 Winthrop Road  
Chester, Connecticut 06412-0684  
Phone: (860) 526-9504  
Fax: (860) 526-4078  
Internet: [www.whelen.com](http://www.whelen.com)  
Sales e-mail: [autosale@whelen.com](mailto:autosale@whelen.com)  
Canadian Sales e-mail: [autocan@whelen.com](mailto:autocan@whelen.com)  
Customer Service e-mail: [custserv@whelen.com](mailto:custserv@whelen.com)

## Installation Guide: Rotating Beacon Model RB6P

### Safety First

This document provides all the necessary information to allow your Whelen product to be properly and safely installed. Before beginning the installation and/or operation of your new product, the installation technician and operator must read this manual completely. Important information is contained herein that could prevent serious injury or damage.

- **Proper installation of this product requires the installer to have a good understanding of automotive electronics, systems and procedures.**
- **If mounting this product requires drilling holes, the installer MUST be sure that no vehicle components or other vital parts could be damaged by the drilling process. Check both sides of the mounting surface before drilling begins. Also de-burr the holes and remove any metal shards or remnants. Install grommets into all wire passage holes.**
- **If this manual states that this product may be mounted with suction cups, magnets, tape or Velcro®, clean the mounting surface with a 50/50 mix of isopropyl alcohol and water and dry thoroughly.**
- **Do not install this product or route any wires in the deployment area of your air bag. Equipment mounted or located in the air bag deployment area will damage or reduce the effectiveness of the air bag, or become a projectile that could cause serious personal injury or death. Refer to your vehicle owner's manual for the air bag deployment area. The User/Installer assumes full responsibility to determine proper mounting location, based on providing ultimate safety to all passengers inside the vehicle.**
- **For this product to operate at optimum efficiency, a good electrical connection to chassis ground must be made. The recommended procedure requires the product ground wire to be connected directly to the NEGATIVE (-) battery post (this does not include products that use cigar power cords).**
- **If this product uses a remote device for activation or control, make sure that this device is located in an area that allows both the vehicle and the device to be operated safely in any driving condition.**
- **Do not attempt to activate or control this device in a hazardous driving situation.**
- **This product contains either strobe light(s), halogen light(s), high-intensity LEDs or a combination of these lights. Do not stare directly into these lights. Momentary blindness and/or eye damage could result.**
- **Use only soap and water to clean the outer lens. Use of other chemicals could result in premature lens cracking (crazing) and discoloration. Lenses in this condition have significantly reduced effectiveness and should be replaced immediately. Inspect and operate this product regularly to confirm its proper operation and mounting condition. Do not use a pressure washer to clean this product.**
- **It is recommended that these instructions be stored in a safe place and referred to when performing maintenance and/or reinstallation of this product.**
- **FAILURE TO FOLLOW THESE SAFETY PRECAUTIONS AND INSTRUCTIONS COULD RESULT IN DAMAGE TO THE PRODUCT OR VEHICLE AND/OR SERIOUS INJURY TO YOU AND YOUR PASSENGERS!**

**For warranty information regarding this product, visit [www.whelen.com/warranty](http://www.whelen.com/warranty)**

## MOUNTING THE UNIT:

The RB6 Series uses a base that may be mounted one of two ways. It is designed to be mounted in a normal dome-up position. If mounted in an inverted position, seal the wire exit hole and any mounting holes with silicone seal.

### 1" N.P.T. PIPE MOUNT:

1. Feed the beacon wires through the pipe.
2. Extend the RED beacon wire to +12VDC and fuse at 5 amps (see warning). Extend the BLACK beacon wire to chassis ground (-). **This unit is polarity sensitive!**
3. Screw the strobe beacon onto the pipe, being careful not to pinch or strain the wires. *Hand tighten* the unit onto pipe.

### PERMANENT SURFACE MOUNT:

**Note:** It will be necessary to remove the dome in order to use this mounting style.

1. Remove the clamp ring securing the dome to the base and remove the dome.
2. Locate the 3 mounting hole indentations on the inside bottom of the base. Drill openings at these locations sized to accommodate the sheet metal mounting screws (customer supplied). Deburr these openings and remove any shavings.
3. Using the base as a template, mark the location of the three mounting holes and wire access hole onto the mounting surface.
4. Using an appropriately sized drill bit (based on the mounting hardware used and the thickness of the mounting surface), drill the three mounting holes marked in step 3. The wire access hole should be drilled using a 1/4" drill bit. Deburr all holes and install a rubber grommet (customer supplied) to protect the wires.
5. Feed the wires through the wire access hole in the mounting gasket, and the mounting surface.
6. Align the mounting holes in the base, gasket, and mounting surface. Fasten with the three sheet metal screws.
7. Extend the RED beacon wire to +12VDC and fuse at 5 amps (see warning). Extend the BLACK beacon wire to chassis ground (-). **This unit is polarity sensitive!**
8. A magnet mount or mirror mount kit is available for purchase separately (see parts list).

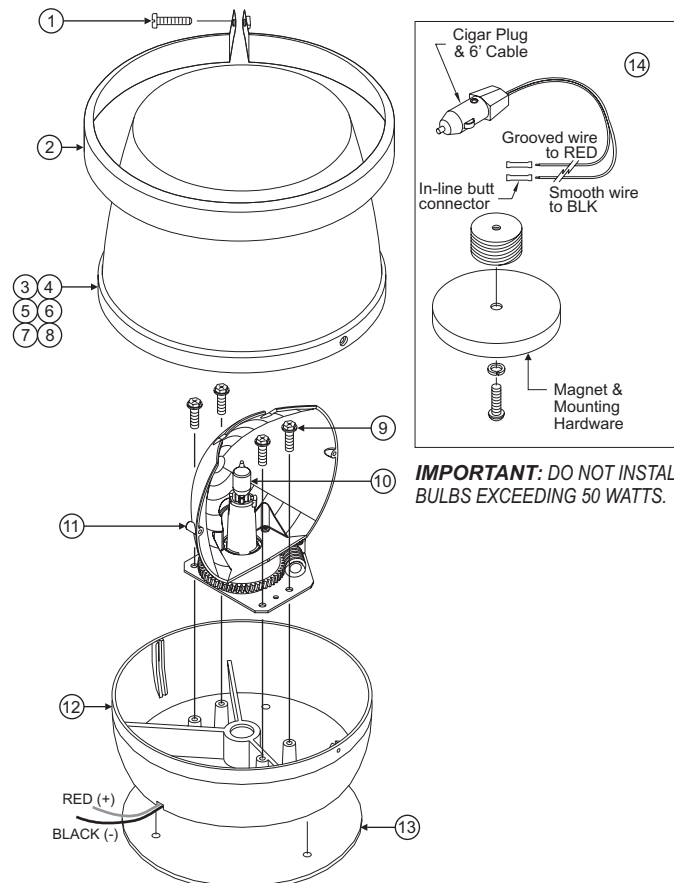

**IMPORTANT: DO NOT INSTALL BULBS EXCEEDING 50 WATTS.**

| QTY. | ITEM | PART NUMBER   | DESCRIPTION                      |
|------|------|---------------|----------------------------------|
| 1    | 1    | 15-101416-120 | #10 X 3/4" PPHSMS TYPE A SCREW   |
| 1    | 2    | 19-261465-000 | CLAMP RING                       |
| A/R  | 3    | 68-4161381-10 | AMBER LENS                       |
| A/R  | 4    | 68-4161381-20 | BLUE LENS                        |
| A/R  | 5    | 68-4161381-30 | CLEAR LENS                       |
| A/R  | 6    | 68-4161381-40 | GREEN LENS                       |
| A/R  | 7    | 68-4161381-50 | RED LENS                         |
| A/R  | 8    | 68-4161381-V0 | VIOLET LENS                      |
| 4    | 9    |               | #8 x 3/8" HEX WASHER HEAD S.M.S. |
| 1    | 10   | 34-0041987-06 | 50 WATT SNAP-IN HALOGEN LAMP     |
| 1    | 11   | 02-0363445-00 | ROTATOR ASSEMBLY                 |
| 1    | 12   | 11-381574-000 | HOUSING BASE                     |
| 1    | 13   | 38-0241504-00 | GASKET                           |
| A/R1 | 14   | 01-2861506-00 | MAGNETIC MOUNT KIT               |
| A/R1 |      | 01-2861522-00 | MIRROR MOUNT KIT                 |

**WARNING:** All customer supplied wires that connect to the positive (+) terminal of the battery must be sized to supply at least 125% of the maximum operating current and fused at the battery to carry that load.

