

Super Strobe® S360D Series

SELF-CONTAINED STROBE BEACON



Premium quality Superstrobe® S360D Series Strobes lead as the most effective, high intensity warning beacons in the business. New exclusive features provide added versatility for a wide range of warning applications.

FEATURES

- Choice of four flash patterns standard in every model: CometFlash®, Double Flash, Rapid Random Flash and Action Flash™.*
- **CROSS-LINK** strobe synchronization allows up to four S360D beacons to flash in simultaneous or alternating pattern.
- Manual High/Low intensity control via external switch.
- AMECA Certified to S.A.E. and California Title XIII requirements.
- Powerful warning with full 30 watts output power.
- Superior visibility. Patented, optic design delivers full illumination of lens area and uniform 360° light dispersion.
- Dual voltage 12/24VDC power supply includes circuits that protect against reverse polarity damage and flash tube ionization.
- Combination permanent and 1" NPT pipe mount cast aluminum base.
- Branch guard models also available.
- Five year, HDP® Warranty on power supply; two year warranty on Gold Medallion flash tube.



Whelen products are proudly made in the U.S.A.



Available in all 5 safety colors

Form# 360D0909

WHELEN^{fi}
Engineers for the Emergency Warning Industry

SUPER STROBE® S360D SERIES STROBE BEACON

SUPERSTROBE® S360D SERIES SPECIFICATIONS

Component optic design features inner optic ring and spreader lens molded inside dome. Top and bottom metalized conical reflectors redirect light energy into horizontal plane, intensifying light pattern. Top reflector doubles as built-in sun shade.



Larger dome provides 36 square inches of frontal illumination. Smooth outer surface resists dirt build-up.

Precision 1-1/2 turn, vertically wound Xenon flash tube and reflector assembly is highly vibration resistant. Plug-in assembly is easily field replaceable. (Model: "SSTUBE")

Nylon clamp ring provides weathertight seal.

Fully enclosed cast aluminum base is available in powder coated satin black (standard) and optional polished aluminum finishes.

Power supply is fully modular and easily field replaceable. Patented clamp circuit prevents power supply damage in the event of flash tube failure.

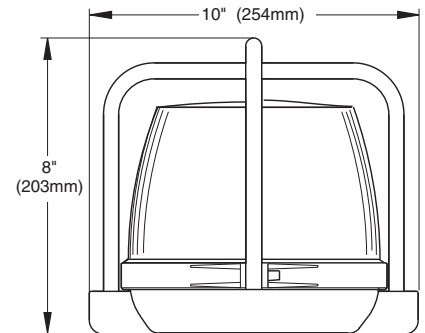
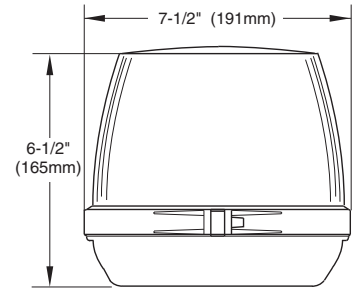

Easy to install with a two wire connection, S360D Series strobe beacons are shipped preset for the CometFlash® flash pattern and high-intensity operation. Internal connectors provide plug-in access to many added operational features using customer supply switches.

CROSS-LINK™ Strobe Synchronization. Connect up to four independent S360D strobe beacons to work as one system. And select either an alternating or simultaneous flash pattern.



ELECTRICAL AND PHYSICAL DATA

Input Voltage.....	12.8VDC / 25.6VDC
Input Current	3.4 amps / 1.7 amps
Input Power.....	43 Watts
Output Power.....	30 Watts
Output Energy	24 joules
	12.6 / 3.8 / 3.8 / 3.8 joules ¹
Effective Candle Power	760 Candela ²
Flashrate	
CometFlash®.....	75 FPM
DoubleFlash	115 FPM
Rapid Random Flash™.....	225 FPM
Action Flash	1 CF - 4 RRF ³
Operating Temperature.....	-30°F (-34°C) to +120°F (49°C)
Weight	3 lbs., 5 oz. (2.4 kg)

1. CometFlash Pattern.
2. Measured in Clear. For peak candlepower, multiply by 13,500.
3. Action Flash™ is a combination pattern that repeats one CometFlash and four Rapid Random Flashes.

MODELS

S360D*P	Permanent/Pipe mount
S360D*B.....	Branch guard mount

*Replace symbol in model number with letter indicating lens color desired:
A=Amber; **B**=Blue; **C**=Clear; **R**=Red; **G**=Green; **S**=Split.

Due to variations in vehicle surfaces and operating conditions, the use of any magnetic mounted warning beacon on the vehicle while in motion is at the discretion and risk of the user.



51 Winthrop Road
 Chester, Connecticut 06412-0684
 (860) 526-9504 • Fax: (860) 526-4078
 www.whelen.com



Whelen Engineering reserves the right to upgrade and improve products without notice.